

NOTES:

1. LOCATE AND SECURE SYSTEM ON FLAT AND LEVEL SURFACE.
2. PLUG ALL OPEN PORTS WITH SQUARE HEAD NPT PIPE PLUGS.
3. CLEARANCE REQUIRED TO SERVICE ITEM #23 IS 12".
5. CLEARANCE REQUIRED TO SERVICE ITEM #24 IS 15".
5. CLEARANCE REQUIRED TO SERVICE ITEM #25 IS 6".
6. CLEARANCE REQUIRED TO SERVICE SEPERATOR ELEMENT (ITEM #26) IS 20".

**EVO2
GENERAL ARRANGEMENT
DRAWING**

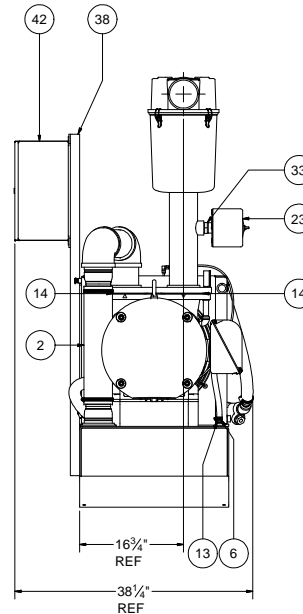
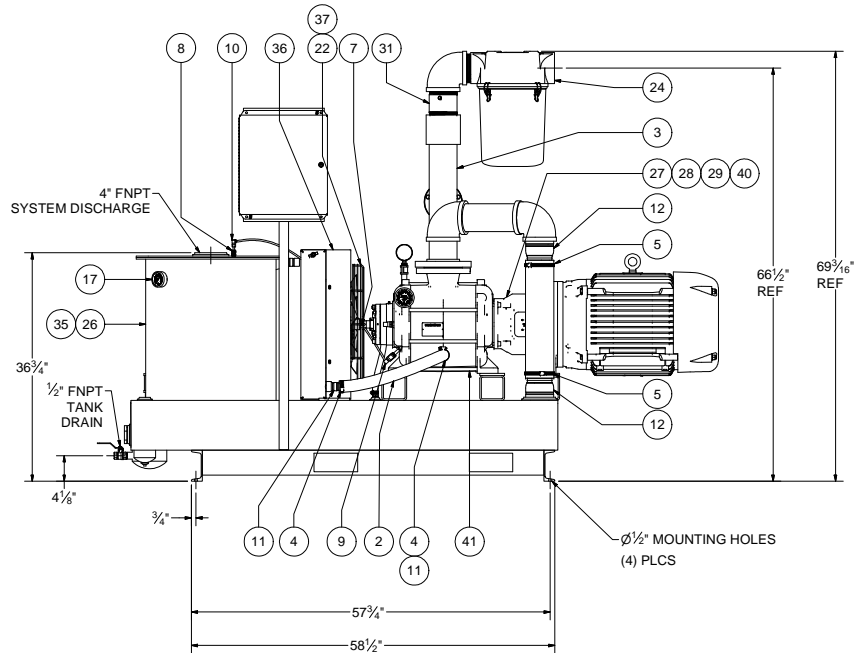

BILL OF MATERIALS			
ITE	QTY	DESCRIPTION	PART NUMBER
1	45 IN.	FLEX, HOSE 1-1/4" ID BLACK RUB	100-0125-0000
2	19 IN.	HOSE FLEX 4" ID X 50 FT LONG	100-0400-1000
3	1	INLET PIPING ASSEMBLY, 4" W/ 1-1/4" HALF COUPLING	1055-1107-1810
4	4	CLAMP, HOSE 1.594" TO 1.812" ID	106-0175-1100
5	2	CLAMP, HOSE WORM GEAR 3" - 5"	106-0500-0000
6	2	CLAMP 9/16" - 1-1/16" DIA. SST	106-0625-1200
7	1	KEY SHAFT 1/4" X 1/4" X 2" LONG	110-0202-0917
8	1	FITTING, 1/4" MNPT X 1/4" TUBE	170-0025-3000
9	1	FITTING, 1/4" MNPT X 1/4" TUBE 90 DEG ELBOW	170-0025-3001
10	1	FITTING, UNION ELBOW BRASS COMPRESSION	170-0025-3002
11	4	FITTING, RED. 1" MNPT X 1-1/4" HOSE	170-0125-3000
12	2	FITTING, ADAP 4" MNPT X 4" ID HOSE	170-0400-3000
13	2	FITTING, 1/2" MNPT X 5/8" ID HOSE	170-0625-3000
14	2	GASKET, FLAT 6.19" OD X 4.57" ID GARLOCK	176-6246-0000
15	1	MOTOR, 40 HP 4P 3PH 230/460V 60Hz TEFC 324TC FTLS STD. EFF.	231-0400-C000
16	1	GAUGE, VAC 0-30" HgV BRASS	400-0025-F000
17	1	GAUGE, PRESSURE 0/15 PSIG BRASS	402-0025-F001
18	1	GAUGE, TEMP 20/240° F 304 SST	410-0050-F001
19	1	SIGHT GLASS WINDOW 2" MNPT	422-0200-0000
20	1	SWITCH, HI-TEMP. N4 NC 225°F	470-0050-C001
21	1	HEAT EXCHANGER, 24X24 1 PASS ALUM/ALUM	535-2424-B001
22	1	FAN, 18" 4-BLADE CLOCKWISE/PULL	550-1804-A000
23	1	FILTER, SILENCER 1-1/4" FNPT 60 SCFM	602-0125-A001
24	1	FILTER, INLINE 4 520 SCFM 5 MICRON	603-0400-A004
25	1	STRAINER, Y 1" FNPT CI 20 MESH	660-0100-C000
26	1	ELEMENT, SEPARATOR 22" OD X 15-1/4" ID	680-0600-A000
27	1	COUPLING, DRIVE 9S 2.125" CI	702-0900-B213
28	1	COUPLING, DRIVE 9S 48MM CI	702-0901-B048
29	1	ELEMENT, COUPLING SIZE 9-JE	752-0900-B001
30	1	VALVE, BALL 1/2" THD. SP BRASS/BRASS/PTFE	801-0050-B000
31	1	VALVE, CK HNG 4" THD CS/BUNA	820-0400-B000
32	1	VALVE, CK SWG .5 THD BRASS	821-0050-F000
33	1	VALVE, VACUUM RELIEF 1-1/4" 316 SST	852-0125-C000
34	1	VALVE, PETCOCK 1/4" MNPT BRASS	890-0025-A000
35	1	EVO2 DYNASEAL SEPARATOR TANK, CS 4" INLET/OUTLET	904-EVO2-A000_C
36	1	SHROUD FOR 18" OD FAN CS	920-0905-0110
37	1	WIRE GUARD FOR 18" OD FAN CS	925-0018-B000
38	1	EVO2 BRACKET CONTROL PANEL OPT	948-1505-0601
39	1	OIL, DYNALUBE 15 GAL. (NOT DRAWN)	971-0022-A000
40	1	ASSEMBLY, M-BLOCK TRVX1007, 324TC	AMB-1007-324T
41	1	TRVX 1007/1Y-C/F W/ STUB SHAFT	RVX1W 00074S
42	1	CONTROL PANEL, SIMPLEX N4 16" X 14" X 8"	ZDY-E500-0000

THIS PRINT IS PROPERTY OF TRAVAINI PUMPS USA, INC. AND MAY NOT BE GIVEN TO ANY OTHER CONCERN WITHOUT THE CONSENT OF TRAVAINI PUMPS USA, INC.

TOLERANCES		PART NO. SX1X10072M13DXS		 Liquid Ring & Rotary Vane Vacuum Pumps and Systems
DECIMAL	± .0025	DWG BY:	DATE	
FRACTIONAL	± 1/16	JM	6/25/15	
ANGULAR	± 0° 30' 00"	JGJ		
UNLESS OTHERWISE SPECIFIED IN DRAWING		APPROVED BY:	SCALE:	MODEL NO.
			1 = 10	EVO 2
				DWG NO. 1506171-D