

GENERAL ARRANGEMENT ONLY

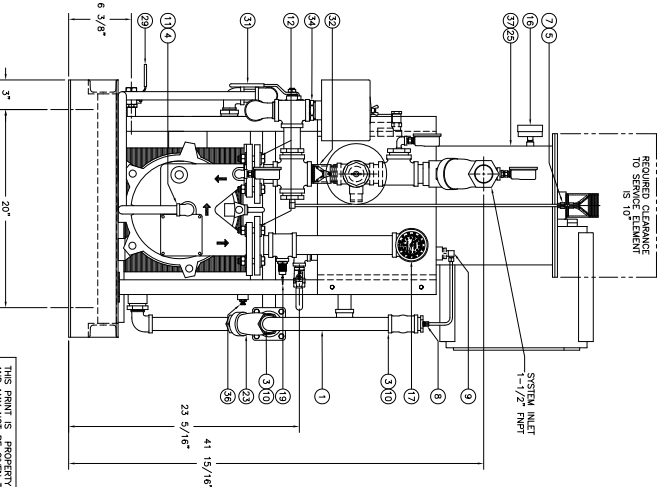
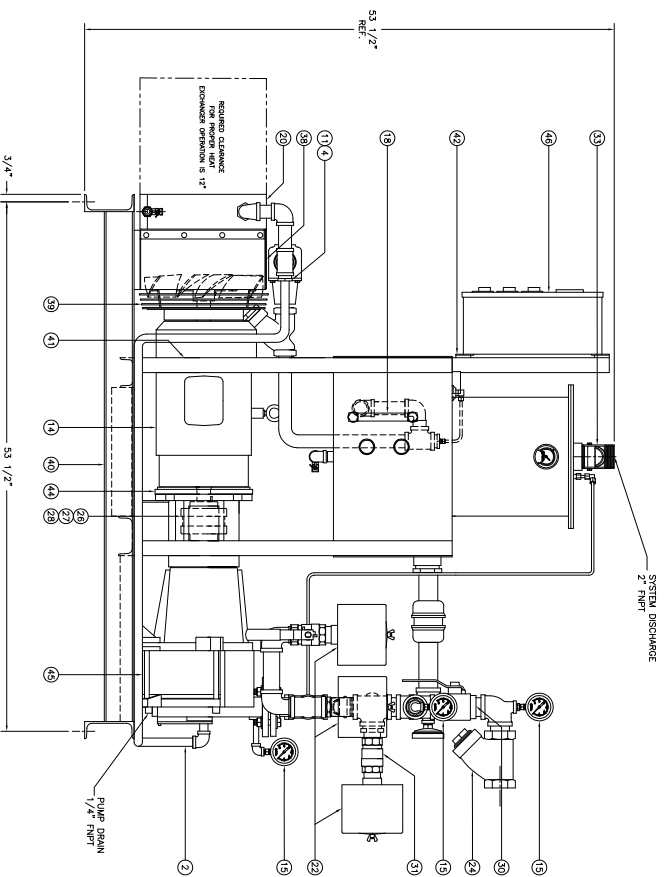
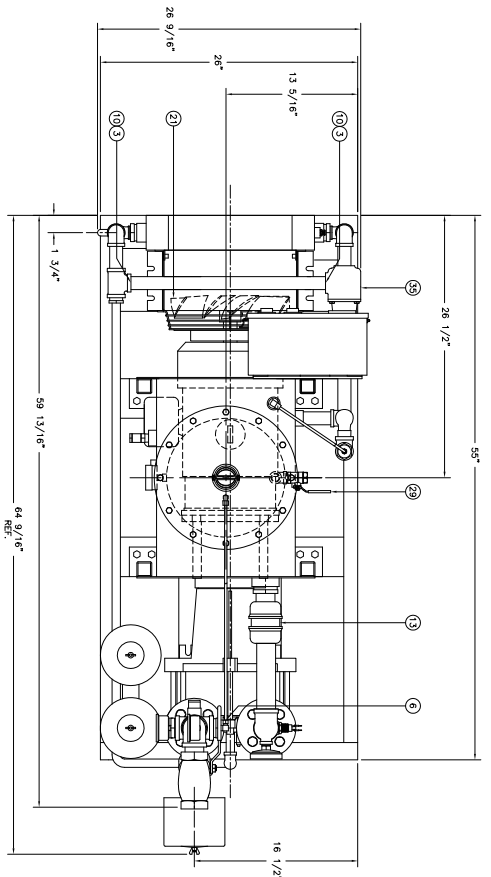

- SYSTEM NOTES:
- 1) LOCATE AND SECURE SYSTEM ON A FLAT LEVEL SURFACE.
 - 2) PLUG ALL UNUSED PORTS WITH SQUARE HEAD NPT PEE PLUGS.
 - 3) OVERALL WIDTH OF SKID IS TO REMAIN UNDER 28".

ITEM	QTY	DESCRIPTION
1	34	FLEX HOSE 1-1/2" ID BLACK RUBBER
2	64	HOSE FLEX 5/8" ID BLACK RUBBER
3	4	CLAMP HOSE 1.594" TO 1.812"
4	2	CLAMP HOSE 5/16" - 1-1/16"
5	1	FITTING 1/4" MPT X 1/4" TUBE
6	1	FITTING 1/4" MPT X 1/4" TUBE 90° ELBOW BRG
7	1	UNION ELBOW BRASS COMPRESSION
8	1	FITTING 1/4" MPT X 1/4" COMPRESSION
9	1	FITTING COMPRESSION 1/4" TUBE X 1/4" MPT 90°
10	4	FITTING, RED, 1/2" MPT X 1-1/4" ID HOSE
11	2	FITTING, RED, 1/2" MPT X 5/8" ID HOSE
12	2	GASSET FLAT 3-1/2" O.D. X 1-5/8" I.D. X 1/16" THK
13	1	FLEX COUPLING 1-1/2" CS/MPT
14	1	MOTOR (HP) 48 TFC 215C W/1-3/8" SMART EXT
15	3	GAUGE WC 0-30"V BRASS 2-1/2" DIA
16	1	GAUGE PRESSURE 0/15PSIG BRASS
17	1	GAUGE TEMPERATURE 20/240-10/110 3" DIA
18	1	GAUGE LEVEL 6" 1/2" MPT AL/BRG/MPT
19	1	SWITCH 6-120V AC NC 225F
20	1	HEAT EXCHANGER 17X12
21	1	FAN 12" TO BLADE CCM/POSH 1-3/8" HUB DIA
22	3	FILTER, SLENDER 1-1/4" 60 SQMM
23	1	STRAINER Y 1" THD CI
24	1	STRAINER Y 1-1/2" THD CI
25	1	SEPARATOR ELEMENT TRO100-180 GALV
26	1	DRIVE COUPLING 75 1-3/8" CI
27	1	DRIVE COUPLING 75 33MM CI
28	1	COUPLING ELEMENT SIZE 7-4E
29	2	VALVE BALL 1/2" THD SP BRG/BRG/PHT
30	1	VALVE BALL 1-1/2" THD CS/PHT
31	2	VALVE BUTTERFLY 1-1/4" THD
32	1	VALVE CHECK INLET 1-1/2" THD CS/L/BRN
33	1	VALVE CHECK INLET 2" THD CS/L/BRN
34	1	VALVE W/COIL REL 1-1/2" BRASS ADJ
35	1	VALVE THERM CONTROL 1" THD 170F CI
36	1	VALVE PETCOCK 1/4" MPT BRG
37	1	SEPARATOR OIL 2" INLET CS
38	1	SHROUD FOR 12" OD FAN
39	1	WIRE GUARD FOR 12" OD FAN ON WTR EXT SHFT
40	1	BASEPLATE OIL FR 55" X 28" X 5" CS
41	3	LEG SEPARATOR 1-1/2" X 3/2"
42	1	LEG CONTROL PANEL 1-1/2" X 48" CS
43	8	OIL DRAINAGE (GAL, NOT SHOWN)
44	1	MANO BLOCK ASSY TRO100 215T
45	1	LIQUID RING VACUUM PUMP
46	1	CONTROL PANEL SIMPLEX M-12 14" X 12" X 6"

THIS PRINT IS PROPERTY OF TRAWANI PUMPS USA, INC. AND MAY NOT BE LOANED TO ANY OTHER CONCERN WITHOUT THE CONSENT OF TRAWANI PUMPS USA, INC.

TOLERANCES

DECIMAL ± .0025"
 FRACTIONAL ± 1/16"
 ANGLE ± 9' 30" 00"

UNLESS OTHERWISE SPECIFIED IN DRAWING

TRAWANI PUMPS USA
 Liquid Ring & Steam Heated Vacuum Pump and Systems

TR0160V-1A
 GENERAL ARRANGEMENT DRAWING

REV	DESCRIPTION	DATE	APPR
1	REVISIONS		