

# pompetravaini

(Rev. 2.2\_07-2015)

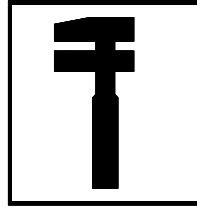

## **DISASSEMBLY AND ASSEMBLY INSTRUCTIONS FOR SELF-PRIMING MULTISTAGE CENTRIFUGAL PUMPS**

### **TBH - AT - TBA**



# INTRODUCTION

These instructions are for the maintenance personnel for maintenance and repair of self-priming multistage pumps series TBH, AT and TBA.

Disassembly and assembly procedures should be carried out by qualified personnel. Prior to working on the pumps the maintenance person should be fully knowledgeable of the material outlined in this manual. Instructions relating to safety of operation, installation and maintenance will be found in the "OPERATING MANUAL FOR CENTRIFUGAL PUMPS" which is usually supplied with the pump or it can be requested from your POMPETRAVAINI representative.

Proper attire is necessary prior to beginning any work on the pumps. Therefore, for your safety, always wear safety hat, eyeglasses, gloves, shoes etc. and be sure to have proper tools necessary for the work to be done.

Do not force or subject pump or any of its components to sudden shocks or violent impact. Do not damage with markings or scratches the mechanical seal surface areas, the engagement surfaces and sealing areas. Do not damage gaskets, and O-Rings. Do not leave in the pump foreign matter such as screws, nuts, bolts, washers, rags, etc.

When requesting spare parts or technical information for the pump, always quote the pump model number and serial number which is printed on the pump nameplate: therefore it is recommended not to remove the pump nameplate or, in case this action will be necessary, write the serial number on the pump (for example on the flange).

Should additional information be required, please do not hesitate to contact POMPETRAVAINI or the closest representative. Should there be any difficulties in repairing the pump, it is recommended to send the pump for repair to POMPETRAVAINI or the local authorised representative.

POMPETRAVAINI will not and cannot be responsible for work done on the pump by the customer or non-authorised personnel.

**NOTE:** Pump parts are identified by item numbers (VDMA). Item numbers can be found in the parts list under chapter 10 and cross-referenced with the sectional drawing under chapter 11.

All drawings given in these instructions are only schematics and not certified.

## INDEX

- 1 - Preparation prior to pump disassembly**
- 2 - Disassembly for bearings and/or mechanical seals replacement**
  - 2.1 - *Disassembly of bearings and mechanical seals pumps without cooling*
  - 2.2 - *Disassembly of bearings and mechanical seals pumps with cooled seal housings*
  - 2.2 - *Disassembly of bearings and mechanical seals pumps with cooled seal housings*
- 3 - Mechanical seals assembly**
  - 3.1 - *Fitting seal stationary part in bearing housing*
  - 3.2 - *Fitting seal rotating part over the shaft*
- 4 - Bearings assembly**
  - 4.1 - *Bearing assembly*
  - 4.2 - *Assembly of sleeve bearing housing at non-drive end for TBH pumps*
- 5 - Pump disassembly**
- 6 - Machining and revision of pump parts**
- 7 - Pump assembly**
  - 7.1 - *Assembly of pumps with outboard ball bearing supports series TBH/C & AT 500/C*
  - 7.2 - *Assembly of pumps with outboard ball bearing supports series AT 650/C*
  - 7.3 - *Assembly of pumps with one outboard ball bearing and one sleeve bearing series TBH/R*
  - 7.4 - *Assembly of pumps series TBA/R*
  - 7.5 - *Assembly of pumps with seal cooling chamber (design /T)*
  - 7.6 - *Assembly of pumps with seal cooling chamber and double mechanical seals back-to-back (design /T)*
  - 7.7 - *Assembly of pumps with seal cooling chamber and double mechanical seals in series (design /T)*
- 8 - Assembly schematics**
  - 8.1 - *Assembly schematic for pumps series TBH & AT 500*
  - 8.2 - *Assembly schematic for pumps series AT 650*
  - 8.3 - *Assembly schematic for pumps series TBA*
- 9 - Spare parts**
- 10 - Parts list**
- 11 - Sectional drawings and auxiliary drawings**



The liquids and gas handled by the pumps and also their parts could be potentially dangerous for persons and environment: provide their eventual disposal in conformity with the laws into force and a proper environment management.



The present manual is not assigned for pumps subjected to the ATEX 94/9/CE directive. In case the pump is assigned in environments subjected to the application ATEX 99/92/CE directive or in case the pump is provided with a nameplate indicating the ATEX stamp, it is strictly forbidden to proceed to start up the pumps but necessary to consult POMPETRAVAINI for clarifications.

For pumps subjected to the ATEX 94/9/CE directive it is available a dedicated integrative manual.

In preparing this manual, every possible effort has been made to help the customer and operator with the proper installation and operation of the pump. Should you find errors, misunderstandings or discrepancies please do not hesitate to bring them to our attention.

## 1 – PREPARATION PRIOR TO PUMP DISASSEMBLY

In the event pump repair is necessary, it is important to be familiar with work to be carried out. See also the attached “Operating Manual for Centrifugal Pumps”.



**FOLLOW THE SAFETY PRECAUTIONS LISTED IN CHAPTER 2 OF ABOVE MANUAL.**

Prior to working on the pump it is important to:

- procure and wear safety attire (hat, glasses, gloves, shoes, etc.)
- disconnect electrical power and, if required, disconnect electrical cable from motor terminal box
- close valves at pump suction and discharge side
- allow pump to cool down if it has been handling hot liquids
- follow safety precautions if hazardous fluids have been handled by the pump
- drain pump casing of any handled liquid through the draining connections and, if required, rinse the pump with neutral liquid.

If it is necessary to remove pump and motor from installation, proceed as follows:

- remove flange bolts from pump suction and discharge connections
- remove the coupling guard
- remove the spacer coupling, if applicable
- if it is required to remove the motor, remove the anchor bolts from the motor feet or (in case of monoblock design) from the motor flange, then remove the motor
- remove the anchor bolts from the pump feet
- remove the pump from the baseplate.

## 2 – DISASSEMBLY FOR BEARINGS AND/OR MECHANICAL SEALS REPLACEMENT

The pumps are designed to allow replacement of ball bearings, sleeve bearings and mechanical seals without total pump disassembly. Therefore it is possible to leave the pump in place without disconnecting the piping or removing the pump from the installation.

Disassembly should follow the steps as outlined for the specific type of pump design.

NOTE: Adopt extra care to prevent damaging of mechanical seal faces and seal components during disassembly.

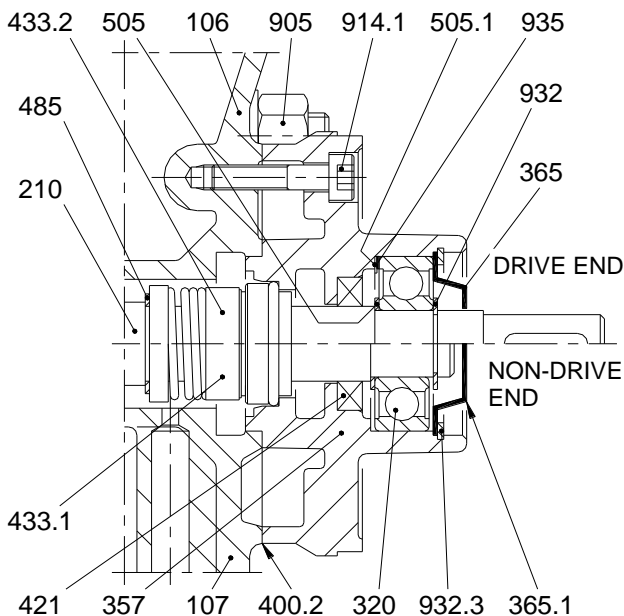

Fig. 1 - Sectional drawing mechanical seal and bearing housing

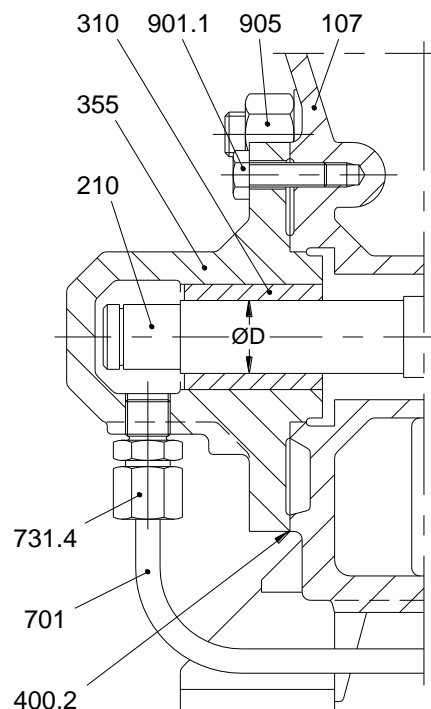

Fig. 2 - Sectional drawing sleeve bearing housing

### 2.1 - DISASSEMBLY OF BEARINGS AND MECHANICAL SEALS PUMPS WITHOUT COOLING

(See fig. 1 for reference to item numbers).

Remove internal snap ring VDMA 932.3, bearing cover VDMA 365 or 365.1, shaft snap ring VDMA 932, bolts VDMA 914.1, bearing housing VDMA 357 (with help of gear puller), ball bearing VDMA 300 or roller bearing VDMA 323,

spacer VDMA 505, elastic ring VDMA 935 which is only at non-drive end side and only if there is a roller bearing, remove the radial seal ring VDMA 421 and finally the mechanical seal VDMA 433.1 or 433.2.

## 2.2 - DISASSEMBLY OF BEARINGS AND MECHANICAL SEALS PUMPS WITH COOLED SEAL HOUSINGS

(See fig. 1 and chapters 10 - 11 for reference to item numbers).

Loosen tube fitting VDMA 731.6 where applicable, remove snap ring VDMA 932.3, bearing cover VDMA 365 or 365.1, snap ring VDMA 932, bolts VDMA 914.1, bearing housing VDMA 357 with the help of a gear puller, bearing VDMA 320, or 323 if roller type, spacer ring VDMA 505, the elastic ring VDMA 935 (at non-drive end and only when roller bearing is used), radial seal ring VDMA 421.

Depending upon the type of mechanical seal arrangement (single, double back to back, double in series) remove the cooling chamber VDMA 116, mechanical seal(s) VDMA 433.2 and 433.1, seal spacer rings VDMA 485 and 485.1, finally seal seat holder VDMA 542. (NOTE: Due to the variety of designs available, the last sequence may differ for certain designs).

## 2.3 - DISASSEMBLY OF SLEEVE BEARING AT N.D.E.

(See fig. 2 for reference to item numbers).

Loosen tube fitting VDMA 731.4 to remove tube VDMA 701, remove bolts VDMA 901.1, sleeve bearing housing VDMA 355 (if required, use bolts VDMA 901.1 as puller through the threaded holes on the bearing housing), finally remove the sleeve bearing VDMA 310 with the help of a suitable puller.

Carefully examine the disassembled items, order only original parts which require replacement such as bearings, sleeves, mechanical seals, gaskets, radial seal rings, etc.

## 3 - MECHANICAL SEALS ASSEMBLY

NOTE: Standard pumps are fitted with mechanical seals unified to DIN 24960/K standard having short working length "L1". For dimensions of non-unified mechanical seals, contact POMPETRAVAINI or the closest representative.

Disassembled parts should be checked prior to fitting mechanical seals VDMA 433.1 and 433.2.

On bearing housing VDMA 357 and/or 357.1 (or seal seat holder VDMA 542), verify dimensions "G" and "F". On shaft VDMA 210 check diameter "D". From casing VDMA 106 and/or 107 to spacer VDMA 485 the dimension "L" should also be verified. Dimensions should be as given by fig. 3 and table 1.

If required corrections must be made to retain the shown dimensions, seal working length "L" (= "L + F") can be attained by working on the spacer VDMA 485 or (where possible) on the shaft VDMA 210.

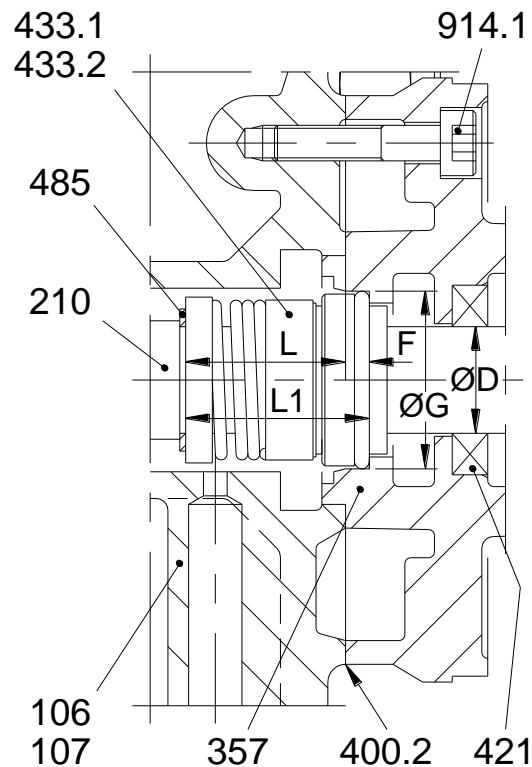

Tab. 1 - MECHANICAL SEAL DIMENSIONS

PUMPS SERIES	Ø D h6	F	Ø G H8	L	L1 ±0,5
TBH & TBA 200	16	4	27	31	35
TBH & TBA 290 to 310	22	2	37	35,5	37,5
TBH & TBA 400 & 500 AT 500 & 650	28	18	43	24,5	42,5
TBH & TBA 650	35	25	50	17,5	

Fig. 3 - Typical mechanical seal with locating dimensions for either pump end (Drive and Non-Drive)

### 3.1 - FITTING SEAL STATIONARY PART IN BEARING HOUSING

The seating area for the seal stationary part and its edges should be perfectly clean and free of tool or machining markings.

Lightly wet the seating area and the O-Ring for the seal stationary part using water, soapy fluid, Vaseline, etc., avoid the use of oils.

Press the seal stationary part (with O-Ring in place) in the seal housing seating area with the help of a plug having the face protected with a soft material such as plastic or paperboard.

Applied force should be vertical to the axis of the part.

A harbour press or the shaft of a drill press can be used for this operation, see fig. 4.

### 3.2 - FITTING SEAL ROTATING PART OVER THE SHAFT

The mechanical seal areas over the pump shaft should be clean, smooth and without sharp edges.

Polish such areas with an extra fine emery cloth prior to applying lubricating fluids such as water, soapy fluid or Vaseline (do not use oils).

Slide seal retainer VDMA 485 over the shaft, slide the total seal rotating part over a conical guiding sleeve "A" or similar tool to help fit the seal over the shaft (see fig. 5), sleeve should also be lubricated with the above mentioned fluids.

The seal rotating part can then be pushed over the shaft by hand or using a sleeve "B" till it rests against the retainer VDMA 585.

**NOTE:** Mechanical seals with conical single springs are designed for a single rotational direction, therefore they must be fitted on pump side which has the proper direction or rotation.

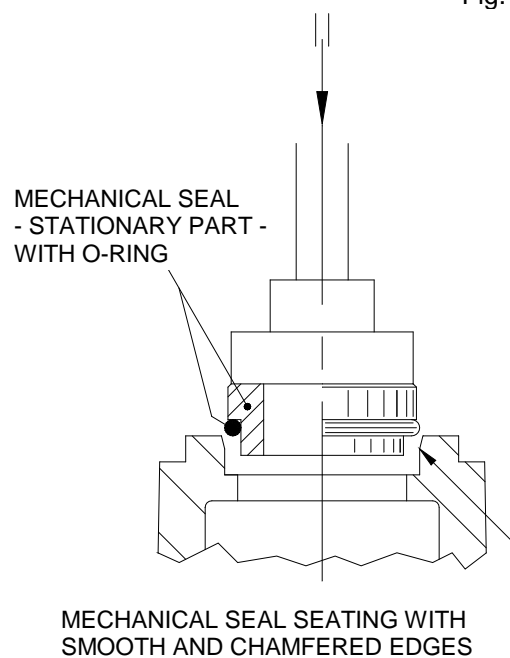

Fig. 5

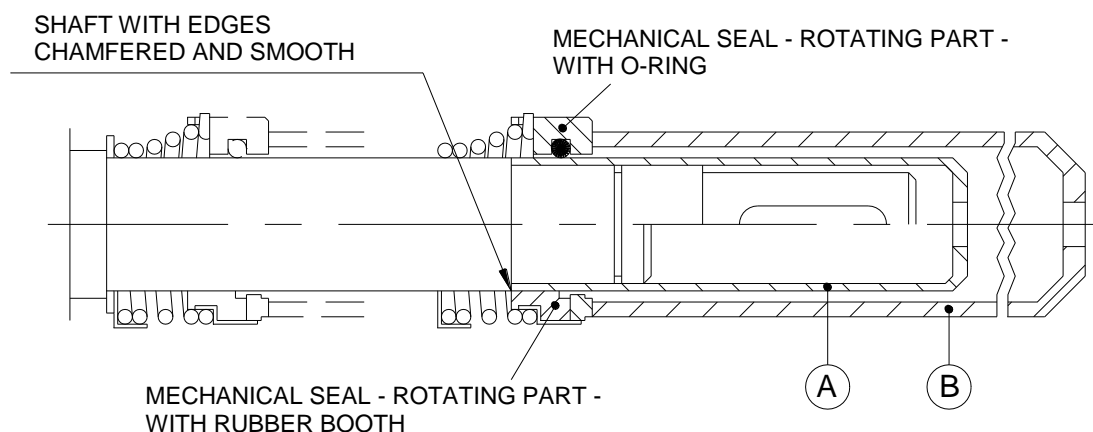
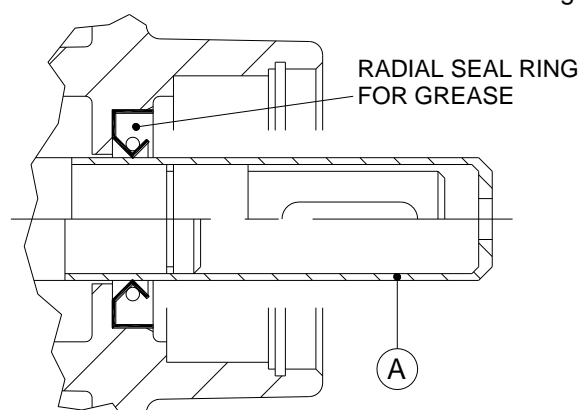

Fig. 6

Install the bearing having VDMA 357 and/or 357.1 complete of radial seal ring VDMA 421 (see fig. 6), seal seat VDMA 542 (where applicable), seal stationary part VDMA 433.1 or 433.2 and gasket VDMA 400.2.

**NOTE:** Bearing housing draining opening should be at bottom (6 o'clock location).

Bolts VDMA 914.1 should be tightened to pump casing VDMA 106 and/or 107.



## 4 - BEARING ASSEMBLY

Bearings can only be fitted after the mechanical seals are in place and the bearing housings are secured per chapter 3.

### 4.1 - BEARING ASSEMBLY

(See fig. 7 and 8 for parts identification).

Slide spacer VDMA 505 over the shaft, place the elastic ring VDMA 935 in the bearing housing. Pumps fitted with roller bearing at drive end will require an elastic ring VDMA 935 also at non-drive end.

Push bearing VDMA 320 (or 323 in case of roller bearing) over the shaft, place the snap ring VDMA 932, the bearing cover VDMA 365 and the snap ring VDMA 932.3.

### 4.2 - ASSEMBLY OF SLEEVE BEARING HOUSING AT NON-DRIVE END FOR "TBH" PUMPS

(See fig. 2 for parts identification).

Where required, replace sleeve bearing VDMA 310 (see table 5 for dimensions of inside diameter), install the sleeve bearing housing VDMA 355 complete of gasket VDMA 400.2, tighten the assembly in place with bolts VDMA 901.1, install tube fitting VDMA 731.4 and tubing VDMA 701.

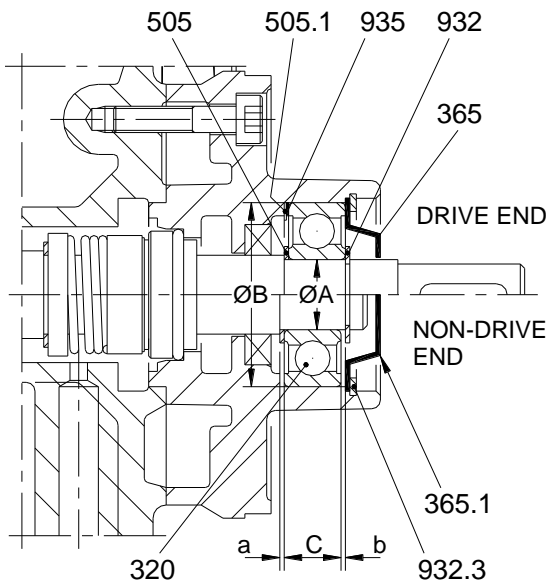

Fig. 7 - "STANDARD" bearing design

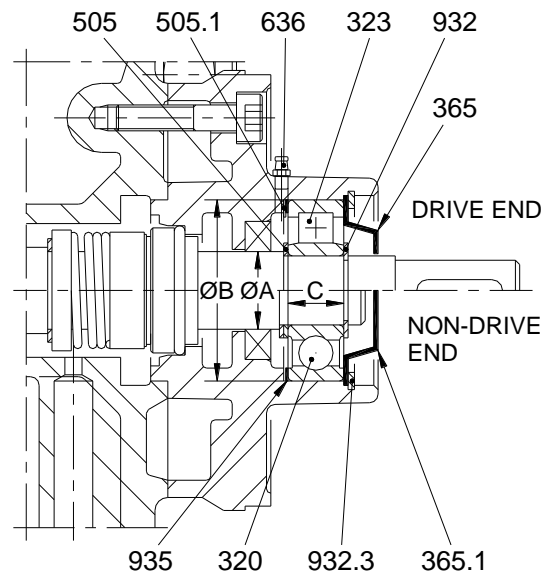

Fig. 8 - Bearing design for "BELT DRIVE ARRANGEMENT"

Tab. 2 - BEARING DIMENSIONS

PUMPS SERIES	a	b	BEARING DIMENSIONS					AMOUNT OF GREASE FOR ROLLER BEARINGS in Grams
			Ø A	Ø B	C	BALL BEARING TYPE	ROLLER BEARING TYPE	
TBH & TBA 200	0,5	1	15	42	13	6302 - 2RS	----	----
TBH & TBA 290 to 310	1		20	52	15	6304 - 2RS	NU 304	12
TBH & TBA 400 & 500 AT 500 & 650			25	62	17	6305 - 2RS	NU 305	15
TBH & TBA 650			1,5	30	72	19	6306 - 2RS	NU 306

## 5 - PUMP DISASSEMBLY

Complete pump disassembly becomes necessary if, for example, there is an excessive wear of impellers which would prevent the pump from performing as expected or if the shaft is excessively damaged in the seal areas causing leakage of the pumped liquid.

Replacing or machining the worn out parts will be a question of economics and/or time available to complete the repair. In this chapter a pump without bearing housing and/or sleeve bearing housing and without mechanical seals will be considered (see fig. 9). Disassembly and assembly of these components have been addressed in chapters 2, 3, & 4.

NOTE: Where the mechanic is not familiar with the pump, it is advisable to draw a reference line along the pump. Mark each part with its location, rotation and assembly sequence; however the main components are already marked at the external upper part with reference logs to provide the proper position (see chapter 8).

Disassembly work should be carried out with proper tools and using suitable disassembly sequence to prevent further damage to the pump parts.

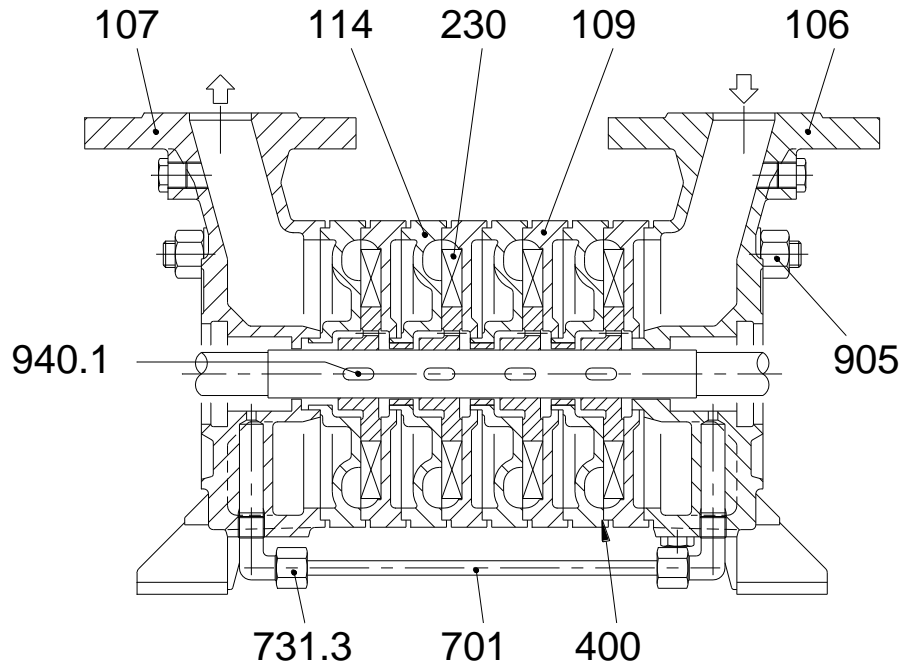

Fig. 9

Loosen and remove the tie-bolts VDMA 905, the tube fittings VDMA 731.3 with tubing VDMA 701, the manifold VDMA 143 (only for AT 650).

Depending upon the pump model, remove suction and discharge casings VDMA 106 and 107, the suction and discharge plates VDMA 109 and 114. Remove the diffuser centrifugal stage VDMA 149 (only for TBA). Remove open impellers VDMA 230, centrifugal impeller VDMA 230.2 (only for TBA) and gaskets VDMA 400 (for TBH 200 also VDMA 400.1).

## 6 - MACHINING AND REVISION OF PUMP PARTS

Machining of internal parts is usually required to remove grooves and/or deformation of working surfaces hence to rebuild the proper internal clearances. Material removal from the surfaces should be minimal and only to reset the proper clearances. Impeller VDMA 230 can be machined on both faces 3 and 4 (if required), max. material to be removed each face is approximately 0,3 mm (see tab. 4 for nominal dimension "A" for impellers).

The surfaces 1, 2, 5, & 6 of the intermediate plates VDMA 109 and 114 (see fig. 10) can also be machined max. 0,3 mm each.

GASKETS BETWEEN THE ELEMENTS "G1"

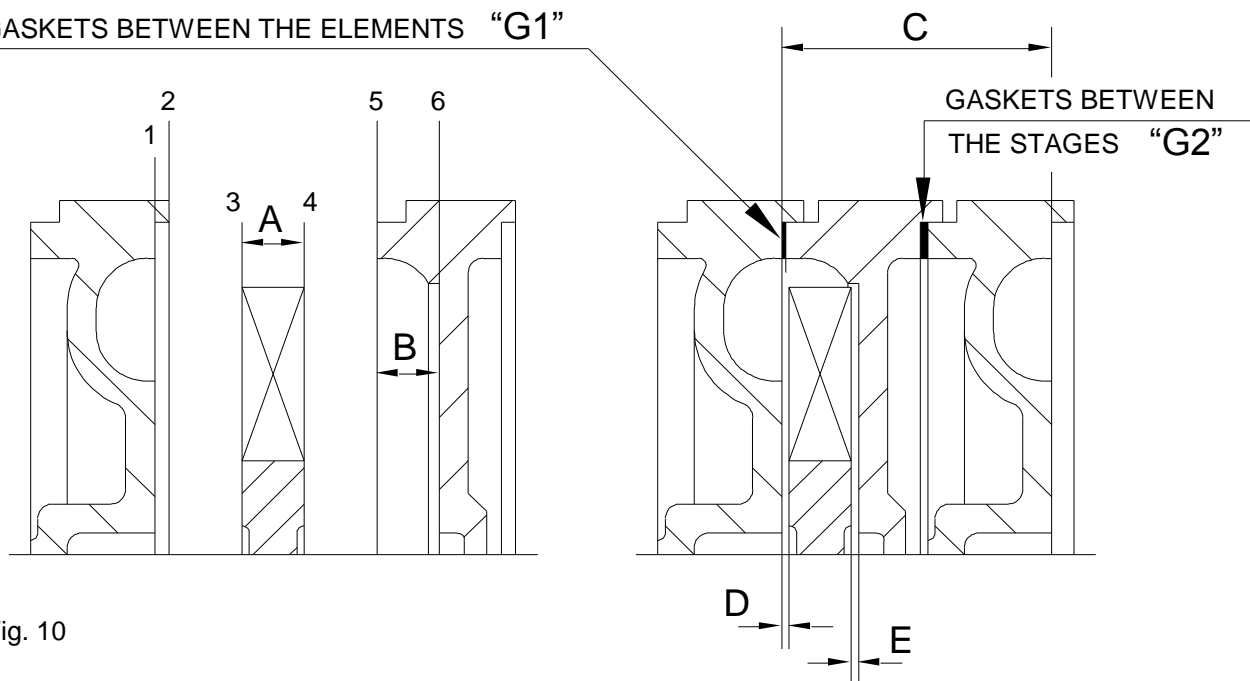

Fig. 10

Tab. 3

DESIGN	GP	GH – GP					RA				B2				A3		
GASKETS "G1"		n° 1 x 0,1 mm					n° 2 x 0,1 mm				N° 1 x 0,1 mm				n° 1 x 0,25 mm		
GASKETS "G2"		n° 1 x 0,1 mm					n° 1 x 0,1 mm				N° 1 x 0,1 mm				n° 1 x 0,25 mm		
PUMPS SERIES	TBA 200	TB H 200	290 ÷ 310	400	500 - 650	TB H 200	290 ÷ 310	400	500 - 650	TB H 200	290 ÷ 310	400	500 - 650	TB H 200	290 ÷ 310	400 ÷ 650	
TOTAL TOLERANCE in mm "D + E"	MIN.	0,18	0,03	0,08	0,10	0,17	0,18	0,20	0,10	0,13	0,18	0,22					
	MAX.	0,23	0,08	0,13	0,15	0,22	0,23	0,25	0,15	0,18	0,22	0,23	0,28				

Tab. 4

DESIGN	GP	GH - GP - RA - B2 - A3					
PUMPS SERIES	TBA 200	TBH 200	TBH & TBA 290 ÷ 310	TBH & TBA 400	TBH & TBA 500	TBH & TBA 650	AT 500 & 650
"C" in mm	33,2	34,2	40,2	55,2	75,2	90,2	85,2
Nominal "A" in mm	10	10	10	15	20	20	25

See table 3 for the allowed total clearance "D + E" and machine surfaces 1, 5, 6 accordingly.

The total clearance "D + E" is given by "B - A + G1".

NOTE: The impeller will self-center between the two plates by hydraulic forces as soon as the pump is started, therefore the clearances "D" and "E" will become identical.

Machining of the pump intermediate plates will decrease the total pump length. If the decrease of pump length is more than 7 mm, re-assembly problems may be encountered. Therefore it is required to maintain dimension "C" (width of each stage) as indicated in tab. 4. Dimension "C" can be rebuilt by adding more gaskets - or using a thicker gasket "G2" as indicated in fig. 10.

NOTE: Machining of the pump internal parts will result in decrease of pump performance especially when the impeller dimension "A" has been decreased.

Certain pumps are fitted with sleeve bearings VDMA 310 or bushings VDMA 310.1. These bushings should be dimensionally checked, see tab. 6 and 7 with fig. 11 and 12.

NOTE.: For pumps series TBA, the diametrical clearance between the centrifugal impeller VDMA 230.2 and the suction casing VDMA 106 should be 0,400 + 0,1/0 mm (clearance on the radius = 0,200 + 0,05/0 mm), see fig. 11.



PUMPS SERIES	Ø D	MATERIAL
TBH 200	16 D7 +0,068 +0,050	Bronze & Graphite
TBH & TBA 290 to 310	22 D7 +0,086	
TBH & TBA 400 & 500	28 D7 +0,065	
TBH & TBA 650	35 D7 +0,105 +0,080	

Tab. 5  
INSIDE DIAMETER OF SLEEVE (VDMA 310) ALREADY PRESSED IN THE BEARING HOUSING OF PUMPS SERIES "TBH" (see fig. 2)

Tab. 6 - INSIDE DIAMETER OF SLEEVE BEARING (VDMA 310) ALREADY PRESSED IN THE CENTRIFUGAL DIFFUSER OF PUMPS SERIES "TBA" (see fig. 11)

PUMPS SERIES	Ø D1	MATERIAL
TBA 200	18 D7 +0,068 +0,050	Graphite
TBA 290 to 310	24 D7 +0,086	
TBA 400 to 650	30 D7 +0,065	

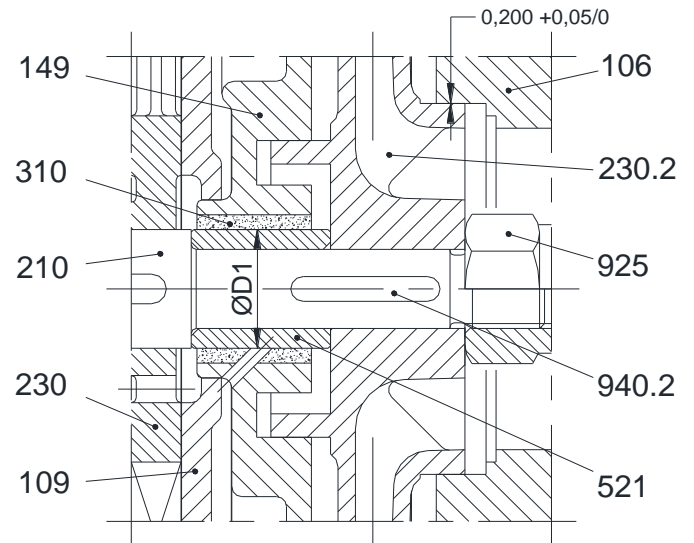

Fig. 11

Tab. 7 - INSIDE DIAMETER OF BUSHINGS (VDMA 310.1) ALREADY PRESSED IN THE ELEMENT PLATES (see fig. 12)

PUMPS SERIES	Ø D2	MATERIAL
TBH 200	18 B9 +0,193 +0,150	Bronze & Graphite
TBH & TBA 290 to 310	24 B9 +0,212 +0,160	Bronze
	24 +0,230 +0,200	Graphite
TBH & TBA 400	30 B9 +0,212 +0,160	Bronze
	30 +0,230 +0,200	Graphite
TBH & TBA 500	32 B9 +0,232 +0,170	Bronze & Graphite
TBH & TBA 650	36 B9 +0,270 +0,230	Graphite
	36 +0,270 +0,230	
AT 500 & 652	30 B9 +0,212 +0,160	Graphite
AT 651 & 652	36 B9 +0,232 +0,170	

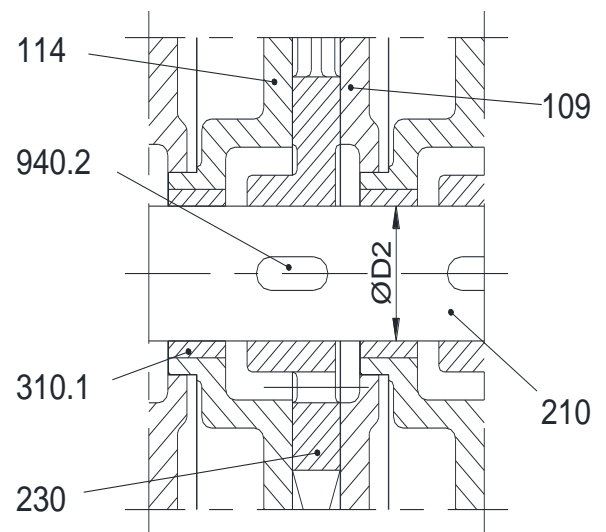

Fig. 12

## 7 - PUMP ASSEMBLY

Inspect every pump component making certain that they are in good condition. If the parts are in acceptable condition, proceed with cleaning procedure using suitable cleaning products. Those parts that are reusable but require machining should be reworked as discussed in chapter 6.

When mixing new original parts with used and re-machined parts, make sure that the dimensions of the later are compatible with those from the original parts. For recommended spare parts see chapter 9.

For mechanical seals assembly see chapter 3. See sections in chapter 11 for identification of the item numbers.

NOTE: Assembly sequence given below assumes that the pump is completely disassembled.

### 7.1 - ASSEMBLY OF PUMPS WITH OUTBOARD BALL BEARING SUPPORTS SERIES BT/C & AT 500/C

- 1 - Place the pump shaft VDMA 210 in a bench vice vertically and with the drive side upward. Insert on the shaft the seal retaining ring VDMA 485. Lubricating shaft and seal rotating part then rotating part of mechanical seal VDMA 433.2. If mechanical seals are with conical springs designed for one specific rotation, the seal to be mounted here is the one for C.W. or right hand shaft rotation. Where applicable, press fit seal seat holder VDMA 542 in the bearing housing VDMA 357 or 357.1. Lubricate (with suitable fluid) the O-Ring of the mechanical seal and press fit the stationary part into the bearing housing.
- 2 - Clean the 2 mechanical seal faces. Insert over the shaft the bearing housing and keep compressed the mechanical seal spring.
- 3 - Insert spacer VDMA 505 over the shaft. Insert spacer VDMA 505.1 and the elastic ring VDMA 935 in the bearing housing. Fit the bearing VDMA 320 on the shaft till it bottoms to the shaft shoulder, block the bearing with snap ring VDMA 932. With a bearing puller, compress the bearing and elastic ring in the bearing housing (this operation helps fitting the bearing cover and relative snap ring). Place the bearing cover VDMA 365 on the bearing housing, fit the snap ring VDMA 932.3 in the bearing housing then remove the bearing housing. Insert the coupling key VDMA 940 in the shaft and remove the shaft from the vice.
- 4 - Place gasket VDMA 400.2 on the bearing housing then slide shaft and bearing housing assembly in the suction casing VDMA 106, then bolt the assembly to the casing with VDMA 914.1. Make sure the draining opening of the bearing housing is located at the bottom.
- 5 - Place the assembly in the vertical position with the shaft drive end locked in a vice and the pump casing flange toward you.

Place the gasket "G2" VDMA 400 on the suction plate keeping it in place with a few drops of compatible oil (see tab. 3 and 4 for gasket thickness and clearances).

Place the suction plate VDMA 109 on the suction casing as indicated in the assembly schematic based on the pumps number of stages (see chapter 8).

NOTE: The schematic is based on the rotation of the sets of plates (suction/discharge) in function of the number of stages, bearing in mind that every stage set, made by one suction and discharge plate plus the impeller, must be assembled with the matching reference grooves of the plates lined up with each other.

Fit on the shaft the key VDMA 940.1 for the first impeller VDMA 230. Slide the impeller on the shaft with the flat part of the blades on the left of the shaft from the observing point, the impeller blades must "bite" into the liquid when rotating, see fig. 13.

NOTE: The key VDMA 940.1 must fit perfectly in the impeller key-way but the impeller must be allowed to freely slide over the shaft.

Place gasket "G1" VDMA 400 on the female side of discharge plate VDMA 114 and fit this on the suction plate with the 2 reference grooves lined up.

- 6 - At this point the steps from point 5 will be repeated as many times as the number of stages to be built. Carefully place the orientation of the suction and discharge plates as illustrated in the schematics of chapter 8.
- 7 - Place gasket "G2" VDMA 400 (or 400.1 for pump series 200) on the discharge casing VDMA 107 and fit the casing on the pump with flange oriented similar to the other flange. Install the tie bolts VDMA 905 and tighten the nuts finger-tight. Place the pump horizontally on its feet on a flat base for alignment. Torque the tie bolts with a torque wrench. Torque moments are listed in tab. 9.

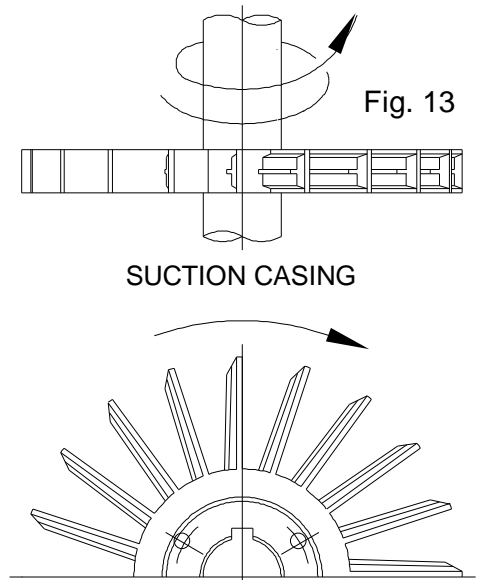

- 8 - Fit seal locating ring VDMA 485 over the shaft, verify that the distance from the shaft shoulder holding the seal and the external face of the discharge casing VDMA 107 is given on tab. 1. If the mechanical seal is not of the type suitable for either direction of rotation, the seal should be suitable for C.C.W. (left) rotation. Properly lubricate the seal rotating part VDMA 433.1 and slide it over the shaft against the locating ring. Lubricate the O-Ring of the seal stationary part and press-fit it in the bearing housing. Clean both seal faces. Install the bearing housing on the discharge casing VDMA 107 with gasket VDMA 400.2 in between and tighten the bolts VDMA 914.1.
- 9 - Insert the spacer VDMA 505 on the shaft so that the bearing inner ring resting against the spacer will be about 1 mm out in relation to the landing face on the bearing housing for the bearing outer ring. Fit the bearing on the shaft and against the spacer. Fit the snap ring VDMA 932 on the shaft. Place the bearing cover VDMA 365.1 on the bearing and secure it with snap ring VDMA 932.3.
- 10 - Be sure that the pump rotor rotates freely by hand. Turn the pump upside down, connect tubing VDMA 701 to the fitting elbows VDMA 731.3 on the 2 casings. Hydrotest the pump to 1,2 times the maximum working pressure for the pump series (NOTE: not the operating pressure) and make sure that there are no leaks.

<p><b>7.2 - ASSEMBLY OF PUMPS WITH OUTBOARD BALL BEARING SUPPORTS</b>  <b>SERIES AT 650/C</b></p>
---

NOTE: Pump Series AT 650/C is built differently from the BT series. The suction cover is on the center of the pump, there are discharge covers at each end of the pump which are connected with a manifold. Pump stages are located between the discharge covers and the central suction cover and are in equal number at both sides of the suction cover. Therefore, this pump series when it has one stage is in fact built with 2 impellers, a 2 stage is built with 4 impellers, etc.

- 1 - Place the shaft in the vertical position in a vice with the drive end down. Insert impeller keys VDMA 940.1 in the shaft keyways.
- 2 - Slide the impeller VDMA 230 on the shaft N.D.E. till it rests against the shaft shoulder, the flat part of the impeller blades should be at your left so that the impeller blades will "bite" into the liquid with the flat side of the blades, see fig. 13. Slide onto the shaft the discharge plate VDMA 114 and position it as illustrated in the assembly schematic (chapter 8) in relation to the pump's number of stages.

NOTE: The schematic is based on the rotation of the sets of plates (suction/discharge) in function of the number of stages; bearing in mind that every stage set, made by one suction and discharge plate plus the impeller, must be assembled with the matching reference grooves of the plates lined up with each other.

- 3 - If it is a 2 stage pump, place in the female side of the suction plate VDMA 109.2 the gasket "G2" VDMA 400 helping it to stay in position with a few drops of oil compatible with the materials (see tab. 3 and 4 for gasket thickness and clearances), slide suction plate and impeller on the shaft, place gasket "G1" VDMA 400 on discharge plate VDMA 114 and insert this on the shaft. If it is a 3 stage pump, repeat the last operation with other parts.
- 4 - If it is a one-stage pump, place the gasket "G2" VDMA 400 in one of the 2 discharge casings VDMA 107 and insert this casing on the shaft placing the reference grooves aligned with those on the suction or discharge plates.
- 5 - Fit seal locating ring VDMA 485 over the shaft, verify that the distance from the shaft shoulder holding the seal and the external face of the discharge casing VDMA 107 is given on tab. 1. Using liquid such as a soapy water solution or Vaseline, lubricate the elastomer parts of the seal. Install the C.C.W. seal rotating part VDMA 433.1 over the shaft (seal suitable for left hand rotation). Press the stationary part of the seal into the bearing housing VDMA 357.1 of N.D.E. Clean both seal faces. Place gasket VDMA 400.2 on bearing housing VDMA 357.1 then install the latter over the shaft and fix to the pump casing VDMA 107 by bolting with the 4 bolts VDMA 914.1. Make sure the drain opening on the bearing housing is located at the bottom.
- 6 - Insert spacer VDMA 505 over the shaft. Install bearing VDMA 320 on the shaft, press it against the shaft shoulder and tighten with bearing nut VDMA 923. Insert spacer VDMA 505.1 and the elastic ring VDMA 935, place bearing cover VDMA 365.1 on the bearing housing and fix it with snap ring VDMA 932.3.
- 7 - Remove the assembly from vice, rotate it 180°, place it upright with the bearing housing VDMA 357.1 down with the flange pointing toward the assembler's body.

NOTE: The assembly will slide downward leaving about 0,5 mm clearance between the impeller and the respective shaft shoulder.

- 8 - Place gasket "G1" VDMA 400 on discharge plate VDMA 114: insert on the shaft the suction plate VDMA 109; place gasket "G2" then install the suction cover VDMA 106 with the flange toward the right side of the assembler.
- 9 - Repeat assembly steps 2, 3 & 4 with gasket "G2", suction plate VDMA 109.1 and impeller VDMA 230. The flat part of impeller blades should be at the right side of the shaft (from the assembler's vantage point). Therefore, the flat part of the blades will always "bite" into the liquid when rotating (see fig. 14 - NOTE: however, for this pump the wording "discharge casing" should be read as "suction casing"). Proceed with gasket "G1" and discharge plate VDMA 114.1. If 2-stage pump, continue with gasket "G2", suction plate VDMA 109.3; impeller VDMA 230, gasket "G1", discharge plate VDMA 114.1. If a 3-stage pump, repeat the last operation with additional parts.
- 10 - If it is a single stage pump, place gasket "G2" VDMA 400 on the other discharge cover VDMA 107, install the latter through the shaft with same orientation as the other discharge cover and with the reference markings in line with those from the other components. Install tie-bolts VDMA 905 and finger tighten the assembly. Place the pump horizontally on a flat surface for alignment. With a torque meter tighten the tie bolts, see tab. 9 for torque value.

- 1 - Slide on the shaft spacer ring VDMA 485, check that the distance from seal shoulder on the shaft and the external face of the discharge cover VDMA 107 is as given in tab. 1.  
Lubricate the seal elastomers and fit the seal rotating part VDMA 433.2 on the shaft. Should the seal be of the single-rotation type, it should then be suitable for right hand rotation, C.W. Lubricate the O-Ring and press the seal stationary ring in the bearing housing. Clean the 2 seal faces. Place gasket VDMA 400.2 on the bearing housing, mount this to the discharge casing VDMA 107 and tighten the 4 bolts VDMA 914.1. Be sure to position the bearing housing with the draining opening toward to bottom.
- 12 - Insert the spacer VDMA 505 on the shaft so that the bearing inner ring when resting against the spacer is about 1 mm out in relation to the landing face on the bearing housing for the bearing outer ring. Fit the bearing on the shaft and against the spacer. Fit the snap ring VDMA 932 on the shaft. Place the bearing cover VDMA 365.1 on the bearing and secure it with snap ring VDMA 932.3.
- 13 - Be sure that the pump rotor rotates freely by hand. Press key VDMA 940 on shaft drive end. Turn the pump upside down, connect tubing VDMA 701 to the fitting elbows VDMA 731.3 on the 2 casings with the "T" fitting on the suction cover.  
Place the pump on its feet, place gaskets VDMA 400.8 on the flanges of discharge covers, install manifold VDMA 147 and tighten with bolts VDMA 901.8.  
Hydrotest the pump to 1,2 times the maximum working pressure for the pump series (NOTE: not the operating pressure) and make sure that there are no leaks.

### **7.3 - ASSEMBLY OF PUMPS WITH ONE OUTBOARD BALL BEARING AND ONE SLEEVE BEARING SERIE TBH/R**

Assembly should be as described under section 7.1 (assembly of pumps with outboard ball bearing supports series TBH/C & AT 500/C) including paragraph 7, then proceed as follows:

- 8 - Place the gasket 400.2 on sleeve bearing housing VDMA 355 and mount the sleeve bearing housing to the discharge cover using bolts VDMA 914.2.  
The fitting VDMA 731.4 should be facing downward.
- 9 - Pump shaft should rotate freely by hand. Turn the pump upside down and connect with tubing VDMA 701 the fitting VDMA 731.3 on the suction cover VDMA 106 with the fitting on the sleeve bearing housing.  
Hydrotest the pump to 1,2 times the maximum working pressure for the pump series (NOTE: not the operating pressure) and make sure that there are no leaks.

NOTE: For pumps of this type handling gas (construction /GP) it is essential to apply "Loctite 573" on both sides of all pump gaskets.

### **7.4 - ASSEMBLY OF PUMPS SERIES TBA/R**

- 1 - Place the pump shaft VDMA 210 in a bench vice vertically and with the drive side upward. Insert on the shaft the seal retaining ring VDMA 485. Lubricate shaft and seal rotating part then insert on the shaft the rotating part of mechanical seal VDMA 433.2. If mechanical seals are with conical springs designed for one specific rotation, the seal to be mounted here is the one for C.C.W. (or left hand) shaft rotation. Lubricate (with suitable fluid) the O-Ring of the mechanical seal and press fit the stationary part into the bearing housing VDMA 357.
- 2 - Clean the 2 mechanical seal faces. Insert over the shaft the bearing housing and keep compressed the mechanical seal spring.
- 3 - Insert spacer VDMA 505 over the shaft. Insert spacer VDMA 505.1 and the elastic ring VDMA 935 in the bearing housing. Fit the bearing VDMA 320 on the shaft till it bottoms to the shaft shoulder, block the bearing with snap ring VDMA 932. With a gear puller, compress the bearing and elastic ring in the bearing housing (this operation helps fitting the bearing cover and relative snap ring). Place the bearing cover VDMA 365 on the bearing housing, fit the snap ring VDMA 932.3 in the bearing housing then remove the gear puller. Insert the coupling key VDMA 940 in the shaft and remove the shaft from the vice.
- 4 - Place gasket VDMA 400.2 on the bearing housing then slide shaft and bearing housing assembly in the discharge casing VDMA 107, then bolt the assembly to the casing with bolts VDMA 914.1. Make sure the draining opening of the bearing housing is located at the bottom.
- 5 - Place the assembly in the vertical position with the shaft drive end locked in a vice and the pump casing flange toward you. Place the gasket "G2" VDMA 400 on the discharge casing VDMA 107 keeping it in place with a few drops of compatible liquid (see tab. 3 and 4 for gasket thickness and clearance).  
Place the discharge plate VDMA 114 on the discharge casing as indicated in the assembly schematic based on the pumps number of stages (see chapter 8).

NOTE: The schematic is based on the rotation of the sets of plates (suction/discharge) in function of the number of stages; bearing in mind that every stage set, made by one suction and discharge plate plus the impeller, must be assembled with the matching reference grooves of the plates lined up with each other.

Fit on the shaft the key VDMA 940.2 for the first impeller VDMA 230. Slide the impeller on the shaft with the flat part of the blades on the right of the shaft from your observing point, the impeller blades must "bite" into the liquid when rotating, see fig. 14.

NOTE: The key VDMA 940.2 must fit perfectly in the impeller key-way but the impeller must be allowed to freely slide over the shaft.

Place gasket "G1" VDMA 400 on the female side of discharge plate VDMA 114 and fit this on the suction plate VDMA 109 with the 2 reference markings lined up.

6 - At this point the steps from point 5 will be repeated as many times as the number of stages to be built. Carefully place the orientation of the suction and discharge plates as illustrated in the schematics of chapter 8.

7 - Place gasket "G2" VDMA 400 on the last suction plate VDMA 109. Insert wear sleeve VDMA 521 over the shaft. Fit on the shaft key VDMA 940.2, then the centrifugal impeller VDMA 230.2.

Introduce the centrifugal diffuser VDMA 149 with the alignment grooves lined up with that for alignment reference of the last suction plate previously mounted. Place the locking washer and lock with left hand threaded nut VDMA 925.

Place a gasket VDMA 400 on the centrifugal diffuser VDMA 149. Fit the suction casing VDMA 106 with feet in same direction as those of discharge casing VDMA 107.

8 - Introduce the 4 tie-bolts VDMA 905 and lock finger tight. Place the pump horizontally on its feet on a flat base for alignment. Torque the tie-bolts with a torque wrench. Torque requirements are listed in tab. 9.

9 - Check that the pump shaft rotates freely by hand.

Turn the pump upside down, connect tubing VDMA 701 to the elbows VDMA 731.3 located at both casings.

Hydrotest the pump to a pressure of minimum 1,2 times the casing design pressure (NOTE: not the operating pressure) and make sure there are no leaks.

NOTE: For pumps of this type handling gas (construction /GP) it is essential to apply "Loctite 573" on both sides of all pump gaskets.

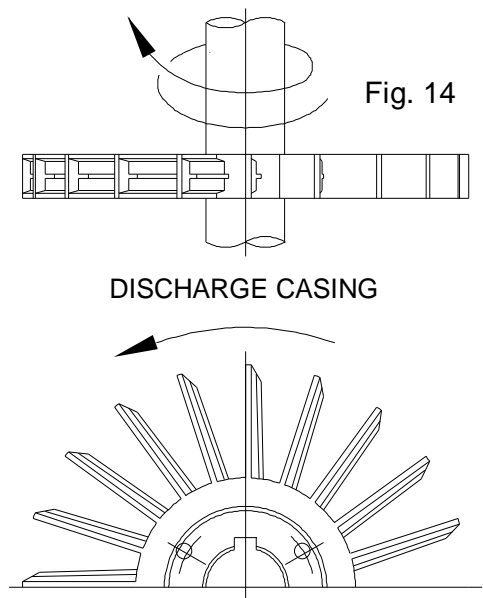

#### 7.5 - ASSEMBLY OF PUMPS WITH SEAL COOLING CHAMBER (Design /T)

1 - Place the pump shaft VDMA 210 in a bench vice vertically and with the drive side upward. Insert and lock at the established position on the shaft the retainer ring VDMA 485 (see fig. 15 and tab. 8). Lubricate shaft and seal rotating part, then install on the shaft rotating part of mechanical seal VDMA 433.2. If mechanical seals are with conical springs designed for one specific rotation, the seal to be mounted here is the one for C.W. (or right hand) shaft rotation (for TBH & AT, C.C.W. for TBA). Lubricate (with suitable fluid) the O-Ring of the mechanical seal and press fit the stationary part into the cooling half-chamber VDMA 116.2.

2 - Clean the 2 seal faces.

Fit on the shaft the cooling half-chamber VDMA 116.2 and bearing housing VDMA 357. Keep the seal spring compressed.

Follow step 3 of paragraph 7.2.

4 - Place gasket VDMA 400.2 on suction casing VDMA 106, install the cooling half-chamber VDMA 116.1. Place gaskets VDMA 400.3 and 400.4 on cooling half-chamber VDMA 116.1.

Centring the pin VDMA 562, fit shaft VDMA 210, cooling half-chamber VDMA 116.2 and bearing housing VDMA 357, lock the assembly with bolts VDMA 914.1.

The seal draining opening on the bearing housing should be placed toward the bottom.

Follow steps 5, 6 & 7 of paragraph 7.1.

8 - Place cooling half-chamber VDMA 116.1 and gasket VDMA 400.2 on discharge casing VDMA 107. Insert and lock at the established position on the shaft the retainer ring VDMA 485 (see fig. 15 and tab. 8).

Lubricate the seal rotating part and fit it on the shaft. For seals suitable for only one direction, this pump end requires left hand seals suitable for C.C.W. rotation (for TBH & AT). Lubricate the O-Ring of seal stationary part and fit this part in the seal cooling chamber. Clean the 2 seal faces.

Place gaskets VDMA 400.3 and 400.4 on cooling half-chamber VDMA 116.1, install the cooling half-chamber VDMA 116.2 and bearing housing, centring the pin VDMA 562. Lock the components with bolts VDMA 914.1.

Seal housing draining connection should be directed toward the bottom.

Follow step 9 of paragraph 7.1.

10 - Check that pump shaft rotates freely by hand.

Turn the pump upside down, connect tubing VDMA 701 to the elbows VDMA 731.6 located at cooling chambers.

Hydrotest the pump to a pressure of minimum 1,2 times the casing design pressure (NOTE: not the operating pressure) and make sure there are no leaks.

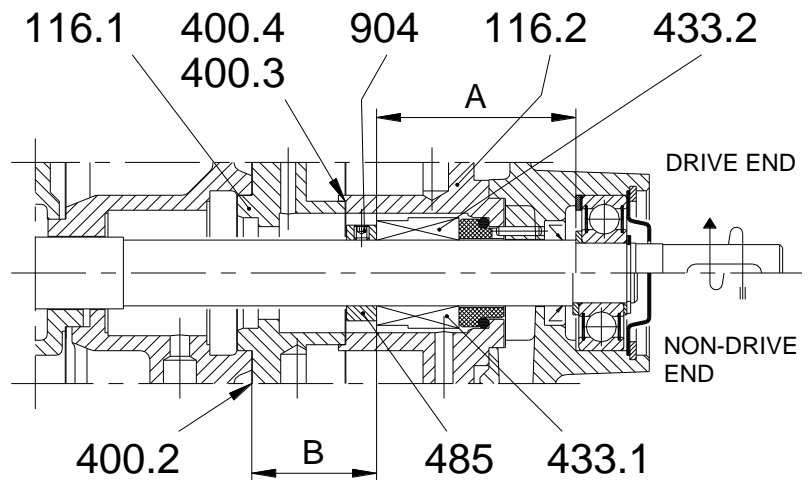

Fig. 15

Tab .8  
POSITION OF MECHANICAL  
SEAL RETAINER RING

PUMPS SERIES	A	B
TBH 200	61,5	42
TBH & TBA 290-310	66,5	41,5
TBH & TBA 400 e 500	79,5	52,75
TBH & TBA 650	85	59,5

**7.6 - ASSEMBLY OF PUMPS WITH SEAL COOLING CHAMBER AND DOUBLE MECHANICAL SEALS  
BACK-TO-BACK (Design /T)**

1 - Place the shaft VDMA 210 in the vertical position in a vice with the drive end upright.  
Lubricate seal rotating part VDMA 433.1 and fit it on the shaft. If the mechanical seal is suitable only for one rotation, the left hand seal for C.C.W. rotation should be used here (for TBH & AT, C.C.W. for TBA).  
Slide and lock at the established position the retainer ring VDMA 485 for the two mechanical seals VDMA 433.2 & 433.1 (see fig. 16 and tab. 8).

Lubricate and fit mechanical seal rotating part VDMA 433.2 on the shaft. This seal should be suitable for right hand rotation, C.W (for TBH & AT, C.C.W. for TBA).

Lubricate the O-Ring of seal stationary part VDMA 433.2 and fit this part in the cooling half-chamber VDMA 116.2.

2 - Clean the 2 seal faces. Fit on the shaft the cooling half-chamber and bearing housing VDMA 357. Keep the seal spring compressed to bottom out.

Proceed as per step 3 of paragraph 7.1.

4 - Lubricate O-Ring on mechanical seal stationary face VDMA 433.1 and fit the latter in cooling half-chamber VDMA 116.1.

Place the gasket VDMA 400.2 and the cooling half-chamber VDMA 116.1 on the suction casing VDMA 106.

Clean the 2 seal faces.

Place gaskets VDMA 400.3 and 400.4 on the cooling half-chamber VDMA 116.1.

Centring the pin VDMA 562, slide assembly of shaft, cooling half-chamber VDMA 116.2 and bearing housing into the cooling half-chamber VDMA 116.1 and lock the assembly with bolts VDMA 914.1.

The seal draining connection on the bearing housing should be directed toward the bottom.

Follow steps 5, 6 & 7 of paragraph 7.1.

8 - Lubricate the O-Ring of seal stationary part VDMA 433.2, fit the latter in the cooling half-chamber VDMA 116.1 and insert gasket VDMA 400.2.

Fit cooling half-chamber VDMA 116.1 in the discharge casing. Clean the 2 seal faces.

Lubricate the seal rotating part VDMA 433.2 and fit it on the shaft. This seal should be suitable for right hand rotation, C.W (for TBH & AT).

Slide and lock at the established position the retainer ring VDMA 485 for the two mechanical seals VDMA 433.1 & 433.2 (see fig. 16 and tab. 8).

Lubricate and fit on the shaft the rotating part of the mechanical seal VDMA 433.1. This seal should be suitable for left hand rotation, C.C.W (for TBH & AT).

Lubricate the O-Ring on the seal stationary part and fit the latter in the cooling half-chamber VDMA 116.2 of non-drive end. Clean the 2 seal faces.

Place gaskets VDMA 400.3 and 400.4 on cooling half-chamber VDMA 116.1, install the cooling half-chamber VDMA 116.2 and bearing housing, centring the pin VDMA 562. Lock the components with bolts VDMA 914.1.

Seal draining opening on bearing housing should be directed toward the bottom.

Follow step 9 of paragraph 7.1.

10 - Verify that the pump shaft rotates freely by hand. Hydrotest the pump at a pressure of minimum 1,2 times the casing design pressure (NOTE: not operating pressure) and check that there is no leakage.

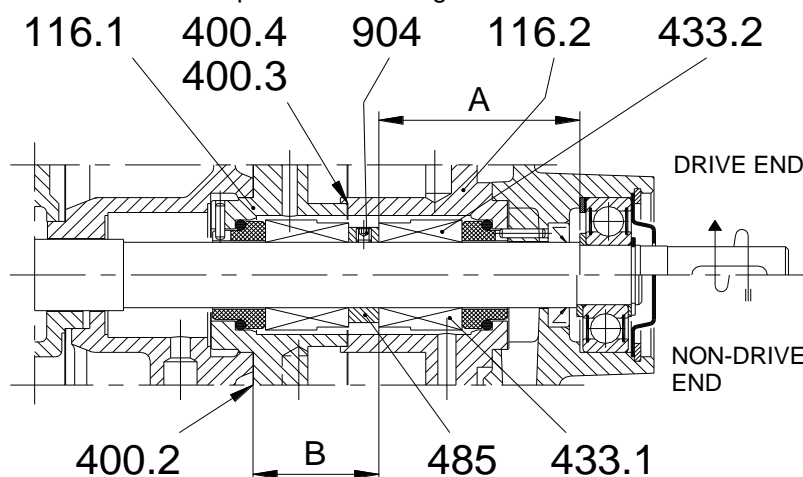

Fig. 16

**7.7 - ASSEMBLY OF PUMPS WITH SEAL COOLING CHAMBER AND DOUBLE MECHANICAL SEALS IN SERIES (Design /T)**

1 - Place the shaft VDMA 210 in a vice vertically and with the drive end upright. Slide seal spacers VDMA 485.1 on the shaft. Lubricate the rotating part of internal mechanical seal VDMA 433.2 and fit it on the shaft. This seal should be suitable for right hand rotation, C.W (for TBH & AT, C.C.W. for TBA). Lubricate the O-Ring of internal seal stationary part.

Press the latter in the cooling half-chamber VDMA 116.1 and add gasket VDMA 400.2.

Clean the 2 seal faces and slide the cooling half-chamber VDMA 116.1 over the shaft. Insert and lock at the established position the retainer ring VDMA 485 (see fig. 17 and tab. 8).

Lubricate the rotating part of external mechanical seal VDMA 433.2 and fit the latter on shaft. This seal should be suitable for right hand rotation, C.W (for TBH & AT, C.C.W. for TBA).

Lubricate the O-Ring of external seal stationary part VDMA 433.2 and fit the latter in the cooling half-chamber VDMA 116.2.

2 - Clean the 2 seal faces. Place gaskets VDMA 400.3 and 400.4 on cooling half-chamber VDMA 116.1.

Centring the pin VDMA 562, slide on the shaft the cooling half-chamber VDMA 116.2 and bearing housing VDMA 357, then keep pressure on the mechanical seal to bottom out.

Follow step 3 of paragraph 7.1.

4 - Place gasket VDMA 400.2 on the suction casing VDMA 106, slide assembly of shaft, 2 cooling half-chamber and bearing housing into the suction casing VDMA 106 and lock the assembly with bolts VDMA 914.1.

The seal draining connection on the bearing housing should be directed toward the bottom.

Follow steps 5, 6 and 7 of paragraph 7.1.

8 - Insert spacers VDMA 485.1 on the shaft, verify the dimension between the seal landing face on the shaft and the external face on the discharge casing VDMA 107 is as given in tab. 1.

Lubricate the internal seal rotating part VDMA 433.1 and fit it on the shaft. This mechanical seal should be suitable for left hand rotation, C.C.W (for TBH & AT).

Lubricate the O-Ring of internal seal stationary part VDMA 433.1 and fit the latter in cooling half-chamber VDMA 116.1, place the gasket VDMA 400.2 on cooling half-chamber. Clean the 2 seal faces and slide the cooling half-chamber VDMA 116.1 over the shaft. Insert and lock at the established position seal locating ring VDMA 485 for the external mechanical seal VDMA 433.1 (see fig. 17 and tab. 8).

Lubricate the rotating part of external mechanical seal VDMA 433.1 and fit it on the shaft. This seal should be suitable for left hand rotation, C.C.W (for TBH & AT). Lubricate the O-Ring of stationary external seal face VDMA 433.1, fit the latter in the cooling half-chamber VDMA 116.2 at non-drive end. Clean the 2 seal faces.

Place gaskets VDMA 400.3 and 400.4 on cooling half-chamber VDMA 116.1, install the cooling half-chamber VDMA 116.2 and bearing housing, centring the pin VDMA 562. Lock the components with bolts VDMA 914.1.

The seal draining opening on the bearing housing should be directed toward the bottom.

Follow step 9 of paragraph 7.1.

10 - Verify the pump shaft rotates freely by hand.

Turn the pump upside down, connect the two fittings VDMA 731.3 on the pump casings with tubing VDMA 701.1.

Hydrotest the pump with pressure minimum 1,2 times the casing design pressure (NOTE: not working pressure) and verify that there is no leakage.

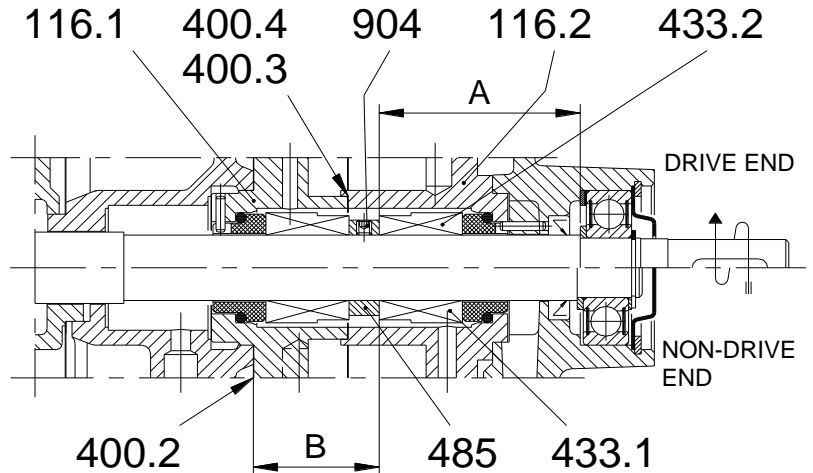

Fig. 17

Tab. 9  
TORQUE VALUES  
FOR TIE-BOLTS

PUMPS SERIES	TORQUE VALUES	
	Kgm	Nm
TBH 200	4,5	44
TBA 200	6	59
AT 500 (1 stage)	8	78,5
AT 500 (from 2 to 8 stages)	10	98
TBH y TBA 290÷310 (from 1 to 8 stages)	8	78,5
TBH y TBA 400 (from 1 to 8 stages)	10	98
TBH y TBA 500 (from 1 to 8 stages)		
AT, TBH y TBA 650 (from 1 to 8 stages)		
TBH 1000 (from 1 to 3 stages)		





**8.2 - ASSEMBLY SCHEMATIC FOR PUMPS SERIES AT 650**

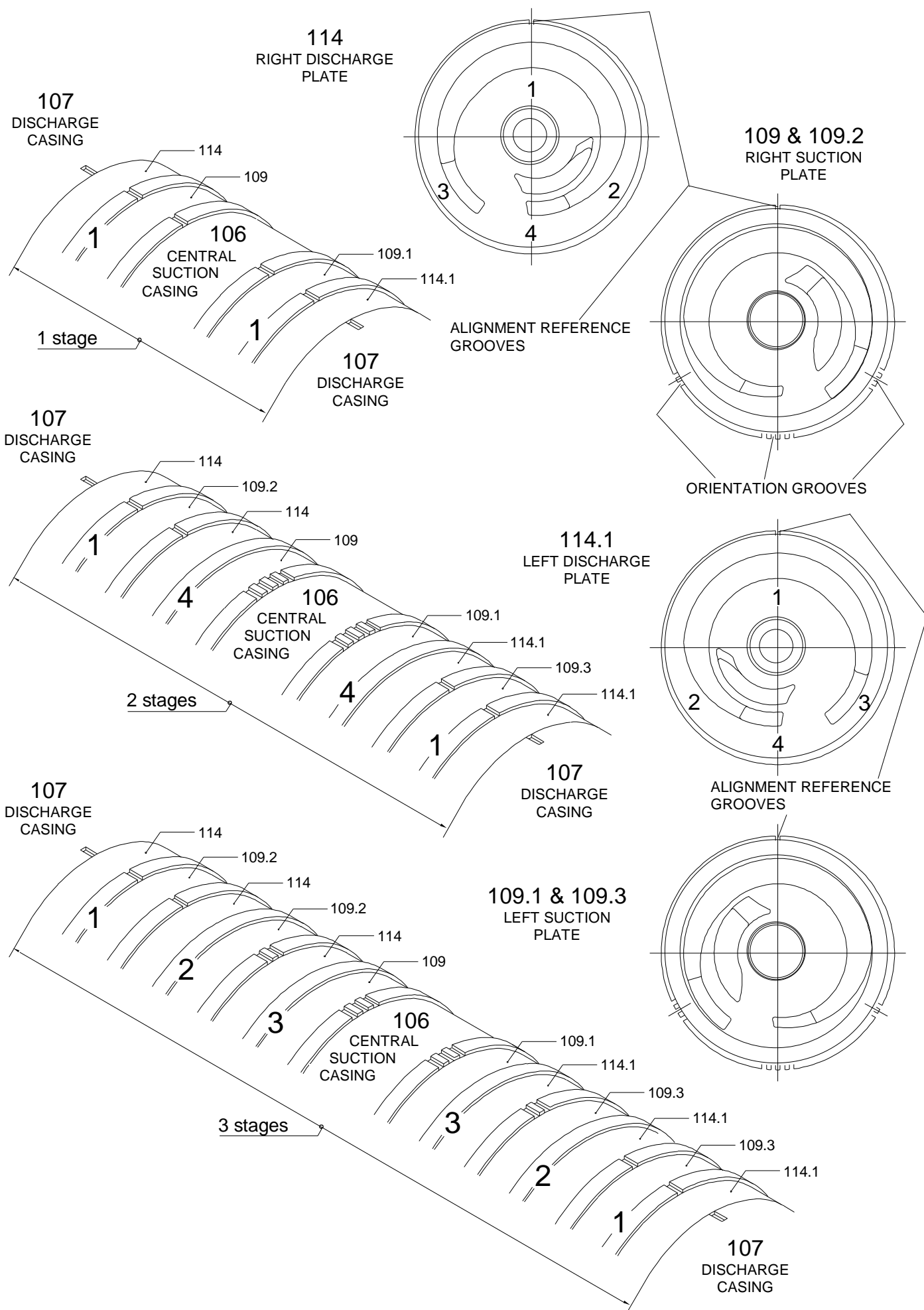



## 9 - SPARE PARTS

When ordering the pump it is good practice to also order the recommended spare parts, especially when there are no stand-by units in the installation. This will minimise unnecessary down times in the event of pump failure.

Therefore, depending upon the type of pump and the number of pumps installed, the quantity of spare parts to be kept on hand should be determined.

Following are the minimum recommended spare parts:

1	Impeller	1	Set packing, where applicable
1	Suction Plate	1	Set mechanical seals, where applicable
1	Discharge Plate	2	Sets gaskets
1	Shaft assembly	1	Set of spacers
1	Bearing set		

When ordering spare parts always provide the information printed on the pump nameplate: Pump model, serial number and year of manufacture.

Provide also the part item number, description and quantity required which is found on sectional drawings (chapter 11) and parts list (chapter 10).

We recommend the use of original spares: in case this is not respected, you lose the right of guarantee and POMPETRAVAINI declines any responsibility.

## 10 - PARTS LIST

VDMA No.	DESCRIPTION
106	Suction casing
107	Discharge casing
109	Suction plate, right
109.1	Suction plate, left
109.2	Suction plate, right
109.3	Suction plate, left
114	Discharge plate, right
114.1	Discharge plate, left
116...	Cooling half-chamber
147	Manifold
149	Centrifugal diffuser
210	Shaft
230	Open impeller
230.2	Centrifugal impeller
310	Sleeve bearing housing
310...	Bushing
320	Ball bearing
323	Roller bearing
355	Sleeve bearing casing
357...	Mechanical seal and bearing housing
365...	Bearing cover
400...	Gasket
400.1	Gasket intermediate plate (TBH 200 only)
421	Radial seal ring
433	Mechanical seal
433.1	Mechanical seal, c. c. w.

VDMA No.	DESCRIPTION
433.2	Mechanical seal, c. w.
485...	Retainer ring, mechanical seal
505...	Spacer ring, bearing
521	Wear sleeve
542	Seal holder
562	Pin
636	Grease nipple
701	Tubing
731.3	Elbow fitting
731.4	Straight fitting
731.5	"T" fitting
731.6	Elbow fitting
735	Nipple
901.1	Screw
901.8	Bolt
904	Grub screw
903	Plug
905	Tie-bolt with washers and nuts
914...	Screw
923	Bearing nut
925	Nut with slot
932	Snap ring for shaft
932.3	Snap ring for bore
935	Elastic ring
940	Key, drive end
940...	Key, impeller

# 11 - SECTIONAL DRAWING AND AUXILIARY DRAWINGS

## SYMBOL LEGEND:

- ➔ Mechanical seal lubrication from external source
- ↔ Mechanical seal lubrication from internal source
- ↕ Cooling liquid from external source
- ↗ Handled liquid

○ Applicable only for S.S. materials (A3) & Bronze (B2)

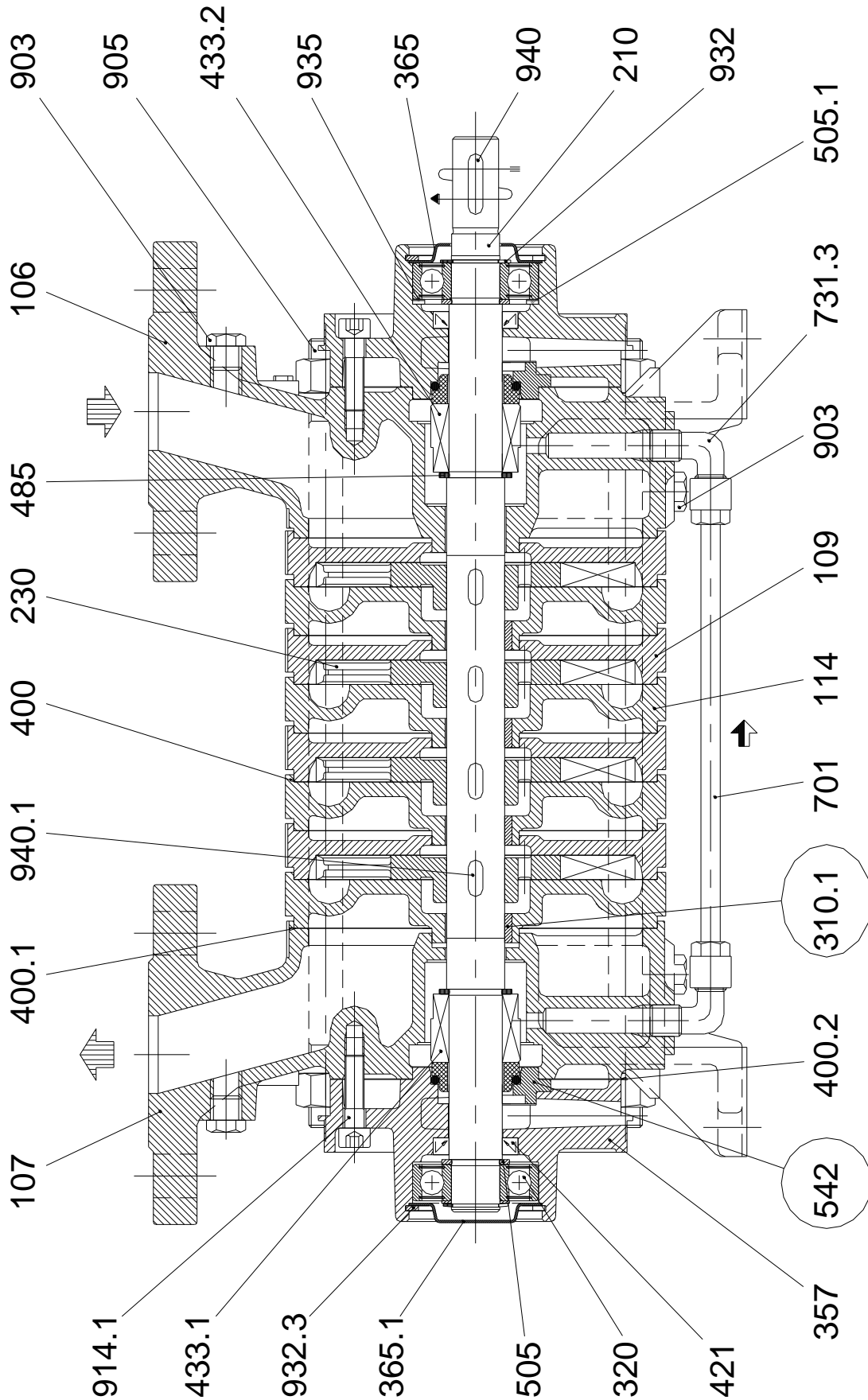

Pumps series TBH & AT 500 design /C

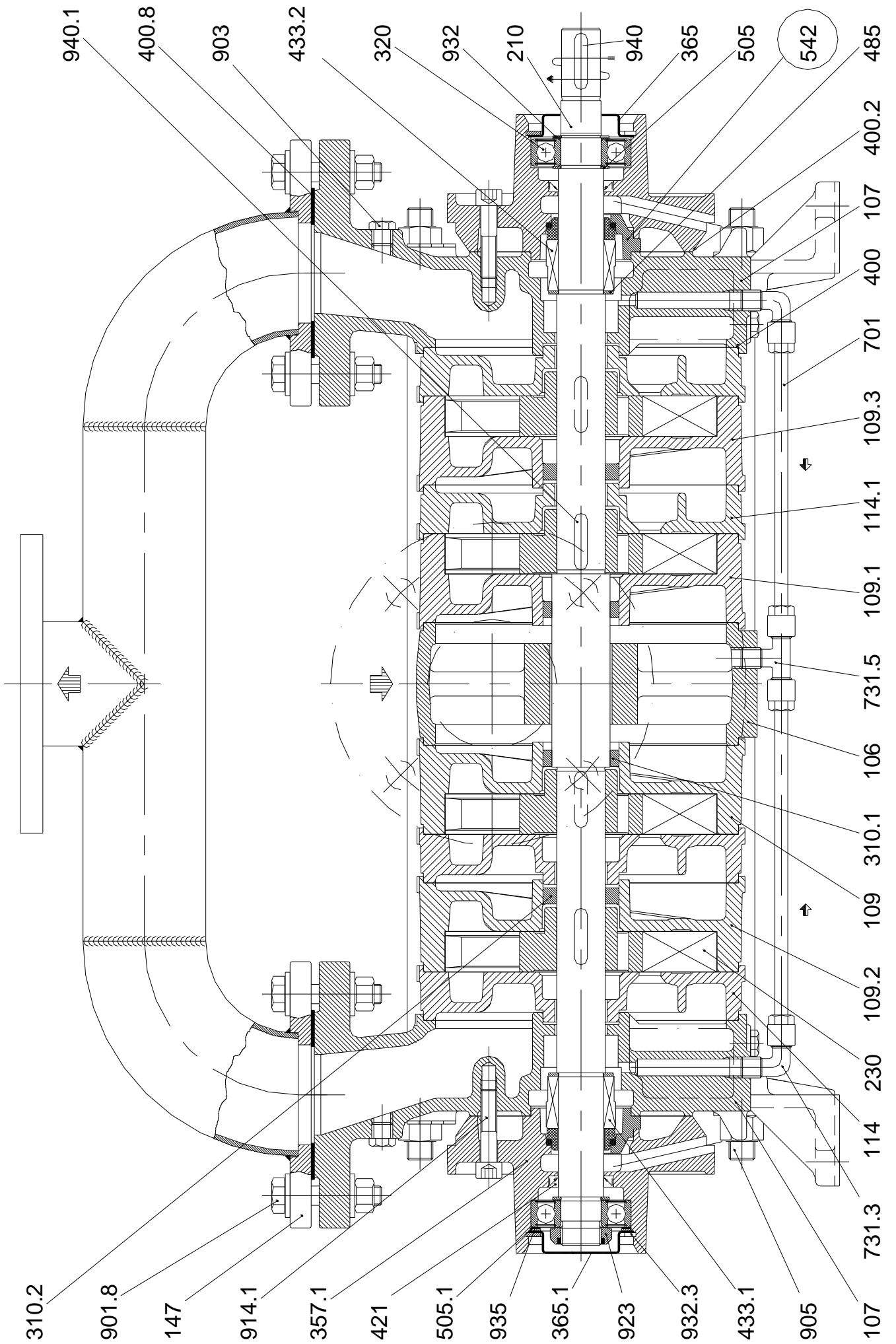

Pump series AT 650/C

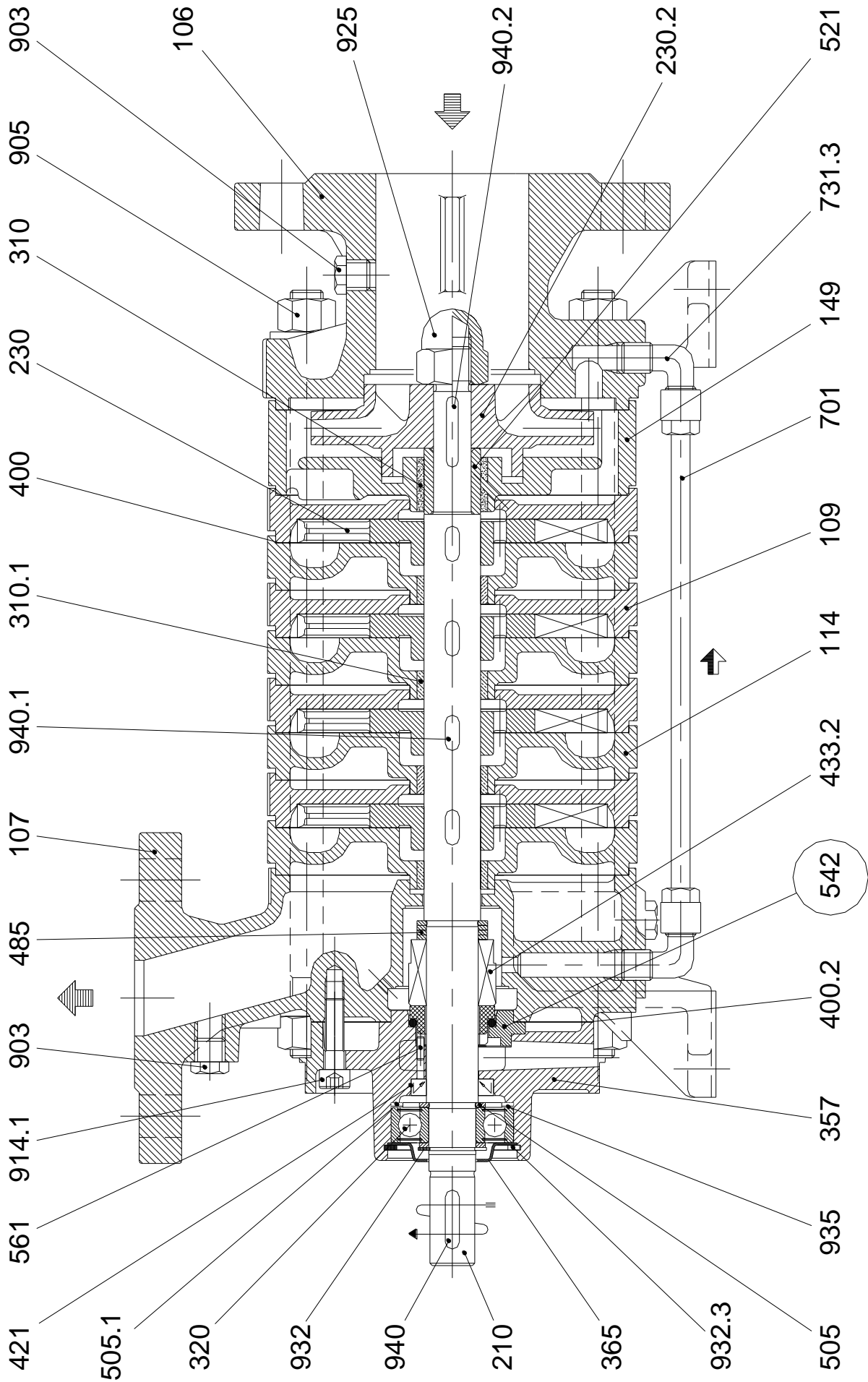

Pumps series TBA 290-300-310/R

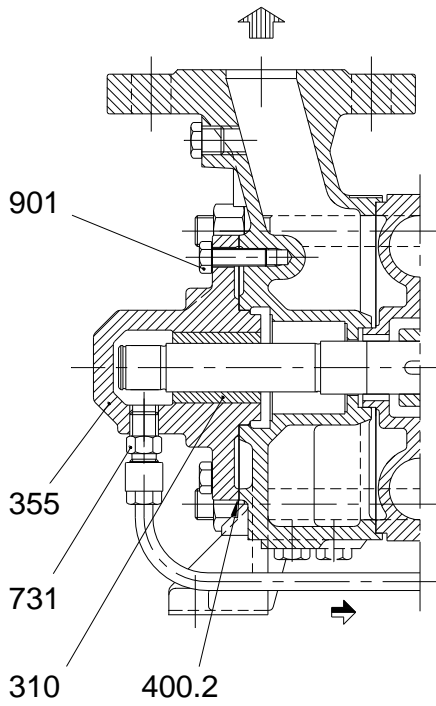

Design .../R  
(with internal sleeve bearing at non-drive end)

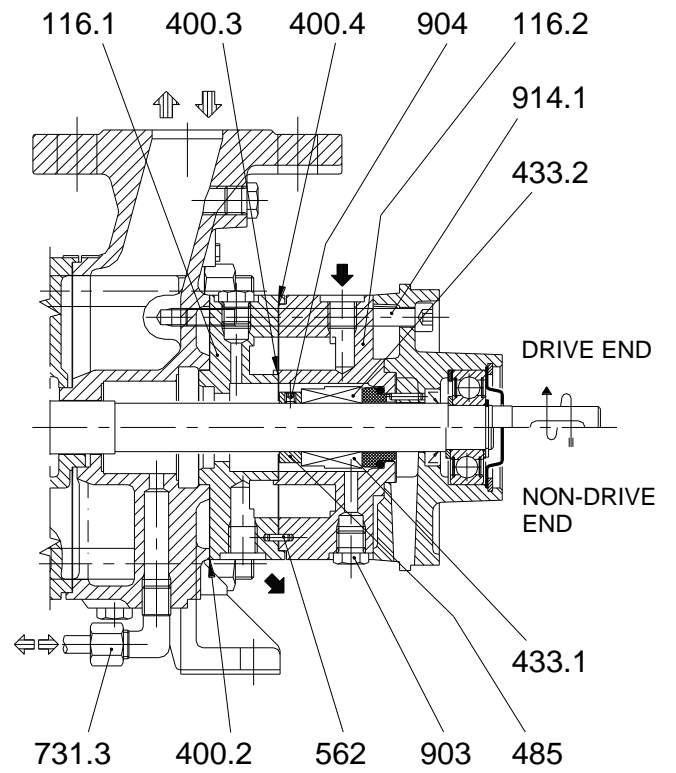

Design .../C.../T or .../R.../T  
(with cooling seal housing)

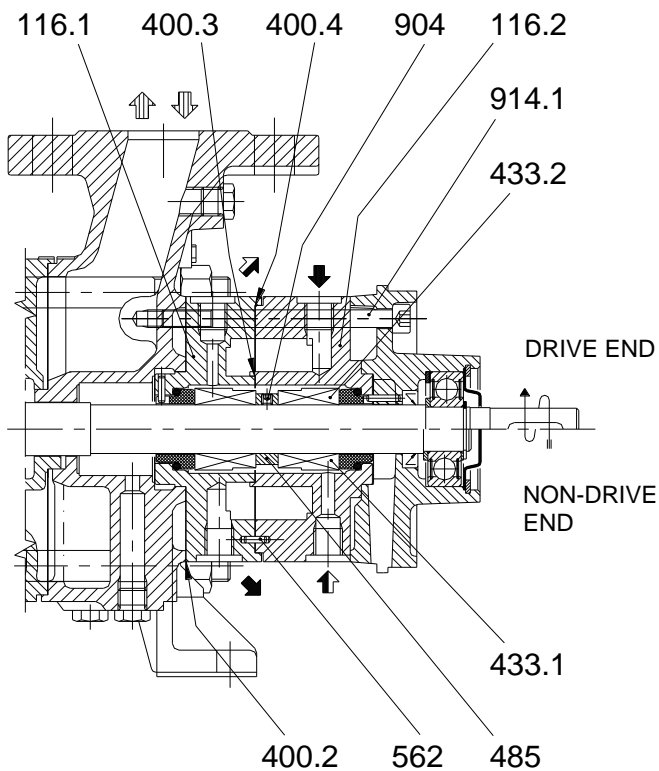

Design .../CC.../T or .../RR.../T (with cooled seal housing and double mechanical seals back-to-back)

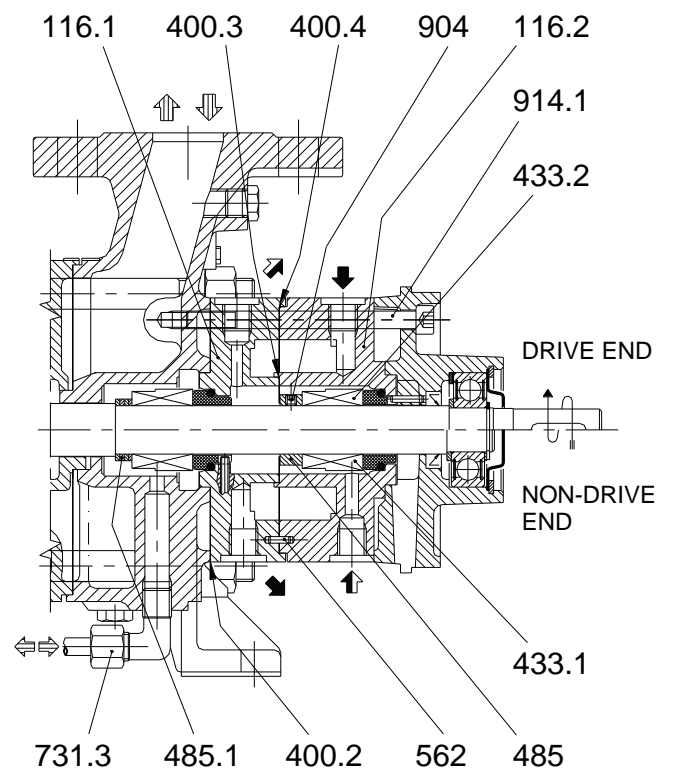

Design .../C2.../T or .../R2.../T (with cooled seal housing and double mechanical seals in series)

**MONOSTAGE CENTRIFUGAL PUMPS**

**MAGNETIC DRIVE  
MONOSTAGE CENTRIFUGAL PUMPS**

**SELF-PRIMING CENTRIFUGAL PUMPS**

**MAGNETIC DRIVE  
SELF-PRIMING CENTRIFUGAL PUMPS**

**MULTISTAGE CENTRIFUGAL PUMPS**

**LIQUID RING VACUUM PUMPS**

**LIQUID RING COMPRESSORS**

**PACKAGE VACUUM UNITS WITH PARTIAL OR TOTAL  
SERVICE LIQUID RECIRCULATION**

NA4.SM.TBHA.GB00 / PRINTED IN ITALY  
Smontaggio TBH-AT-TBA Inglese

Continuing research of POMPETRAVAINI results in product improvements: therefore any specifications may be subject to change without notice.

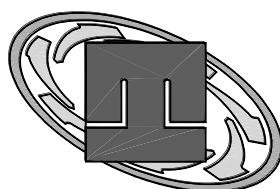
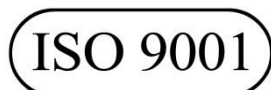

**pompetravaini** S.p.A.  
20022 CASTANO PRIMO (Milano) ITALY  
Via per Turbigo, 44 – Zona Industriale  
Tel. 0331 889000 – Fax 0331 889090  
[www.pompetravaini.com](http://www.pompetravaini.com)