

DIMENSIONI D'INGOMBRO
Overall dimensions
POMPE CENTRIFUGHE AUTOADESCANTI
Self-priming centrifugal pumps
SERIE
Series TBH 1000/2-C



200 Newsome Drive
Yorktown, VA 23693
1-800-535-4243
www.Travaini.com

Versione ad ASSE NUDO
BARESHAFT construction

FLANGE SECONDO UNI 2223-2229-PN 16
Flanges according to UNI 2223-2229-NP 16

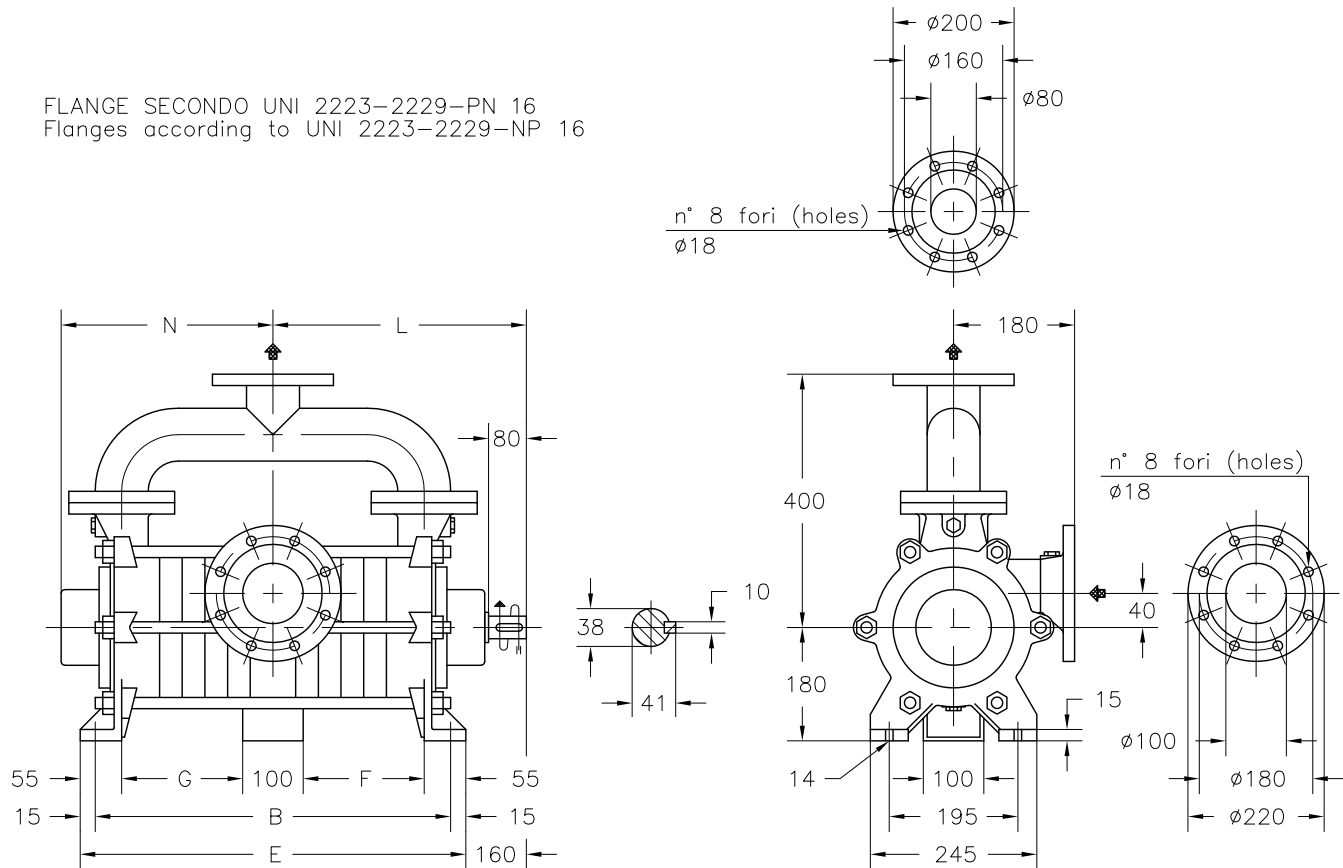

POMPE TIPO Pumps type	B	E	F	G	L	N	PESO Weight
TBH 1001/2-C	480	510	150	150	410	320	111
TBH 1002/2-C	660	690	240	240	500	410	134
TBH 1003/2-C	840	870	330	330	590	500	157

DISEGNO SCHEMATICO - DIMENSIONI IN MM. CON TOLLERANZE SECONDO EN 735-1995 E PESI IN KG. NON IMPEGNATIVI
Schematic drawing - Dimensions in mm. with tolerances according to EN 735-1995 and weights in kgs. not binding

I PESI SONO RIFERITI A POMPE IN ESECUZIONE GHISA (GH)
The weights are referred to Cast Iron (GH) construction

RIF.-Ref.: F.P./C.T.

SOSTITUISCE-Replaces: 1039.2L1.201.03

DATA-Date: FEBBRAIO 2008 - February 2008

N°.: 1039.2L1.201.04



Versione **ACCOPPIATA (BASE-GIUNTO)**
COUPLED construction (BASEPLATE-COUPLING)

FLANGE SECONDO UNI 2223-2229 PN 16
 Flanges according to UNI 2223-2229 NP 16

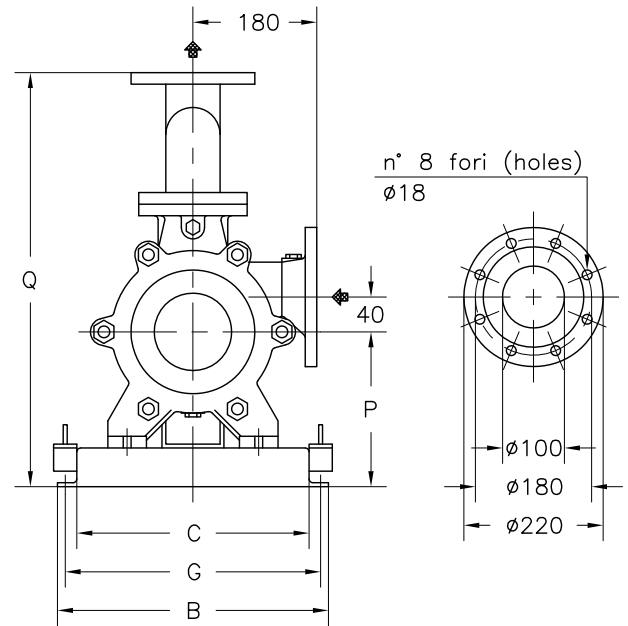
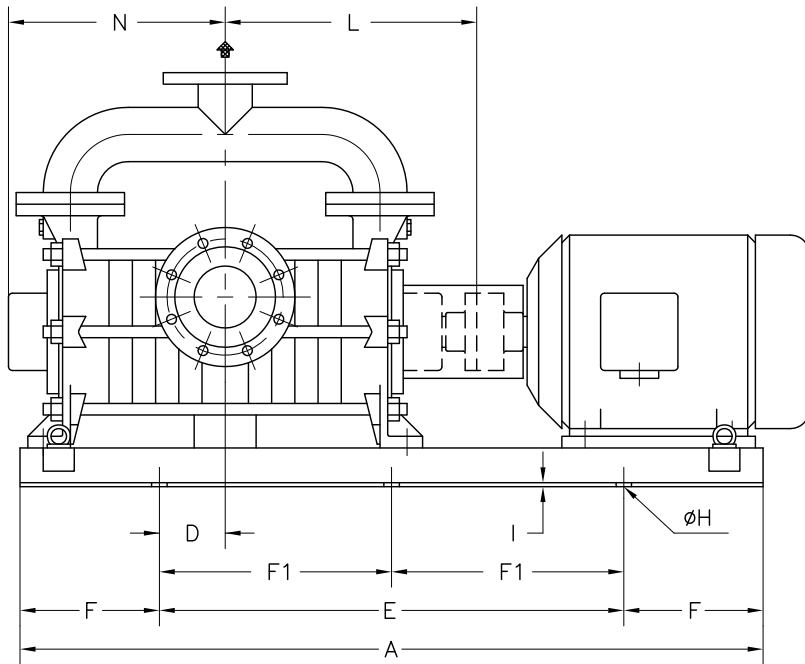
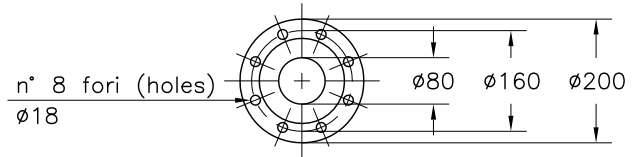

POMPA TIPO Pump type	MOTORI A 4 POLI 4 Poles Motors UNEL-MEC-B3		BASE N°	DIMENSIONI Dimensions										PESO Weight ①							
	TIPO Type	KW		BASAMENTO Baseplate											POMPA/MOTORE Pump/Motor						
				A	B	C	D	E	F	F1	G	H	I		L	N	P	Q			
TBH 1001/2-C	132 M	9	903	1170	410	350	115	770	200	-	380	14	6	410	320	270	670	165			
	160 M	11	906	1400			135	950	225							310	710	205			
	160 L	15	041	1350	560	420	100	900			510	330	730						220		
	180 M	18,5					75	180	1100							300	540	310		710	240
	180 L	22					150														
200 L	30	042	1800	640	500	200	1400	200	700	590	18	7	500	410	355	755	250				
TBH 1002/2-C	180 M	18,5	034	1700	590	450	180	1100	300	-	540	18	7	500	410	310	710	240			
	180 L	22					330									730	255				
	200 L	30	042	1800	640	500	260	1400	200	700	590	590	500	500	355	755	298				
	225 S	37																380	780	328	
225 M	45	039	2150	680	540	290	1600	275	800	630	590	500	500	417	1117	310					
280 S	75																				
280 M	90																				
TBH 1003/2-C	180 L	22	034	1700	590	450	155	1100	300	-	540	590	500	500	310	710	263				
	200 L	30																330	730	278	
	225 S	37	042	1800	640	500	260	1400	200	700	590	590	500	500	355	755	298				
	225 M	45																380	780	328	
	250 M	55	039	2150	680	540	290	1600	275	800	630	590	500	500	417	1117	310				
	280 S	75																			
280 M	90																				

DISEGNO SCHEMATICO - DIMENSIONI IN MM. CON TOLLERANZE SECONDO EN 735-1995 E PESI IN KG. NON IMPEGNATIVI
 Schematic drawing - Dimensions in mm. with tolerances according to EN 735-1995 and weights in kgs. not binding

I PESI SONO RIFERITI A POMPE IN ESECUZIONE GHISA (GH)
 The weights are referred to Cast Iron (GH) construction

① PESO ESCLUSO MOTORE
 Weight without motor