

PVL10 - PVL10/B (PVL15 - PVL15/B)

NOTICE: This document contains references to "PVR". Please note that PVR was acquired by Agilent Technologies in January 2012. For more information about these products and support, go to www.agilent.com/chem/vacuum.

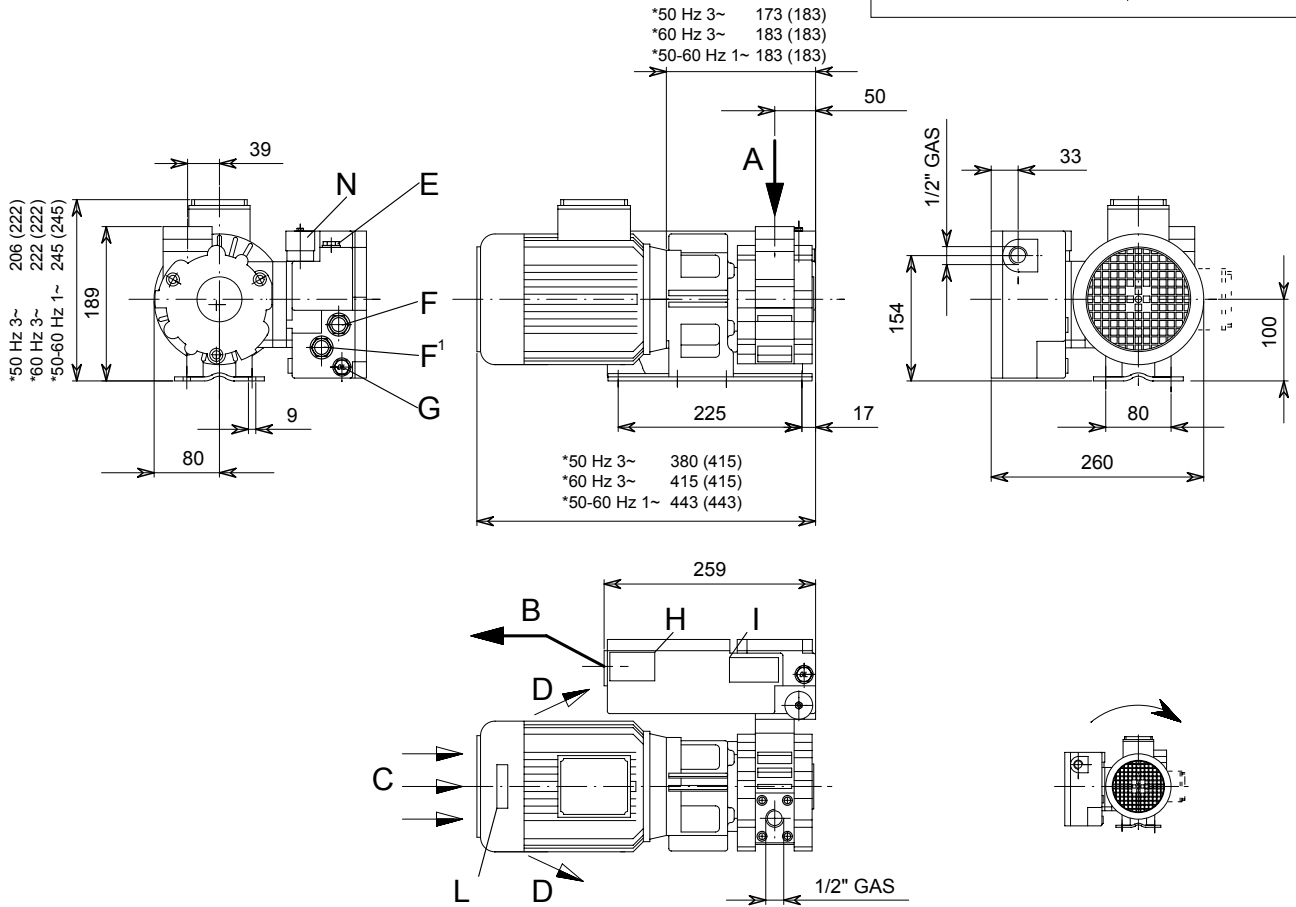

*Misure soggette a variazioni in funzione della marca del motore
 *Dimensions subject to changes depending on the motor brand
 *Données sujettes aux variations en fonction de la marque du moteur

*Die Maße können auf Grund vom Motorzeichen ändern
 *Medidas sujetas a variación en función de la marca del motor

(I) (GB) (F) (D) (E)

A	Aspirazione	Inlet	Aspiration	Einlass	Aspiración
B	Scarico aria	Air outlet	Sortie de l'air	Luftauslass	Salida de aire
C	Entrata aria raffreddamento	Cooling air inlet	Entrée air refroidissement	Kühlluftseintritt	Entrada aire refrigeración
D	Uscita aria raffreddamento	Cooling air outlet	Sortie air refroidissement	Kühlluftaustritt	Salida aire refrigeración
E	Tappo carico olio	Oil filling plug	Bouchon remplissage huile	Öleinfüllschraube	Tapón carga de aceite
F	Spia livello olio max.	Max. oil level sight glass	Contrôle niveau huile maximum	Höchstölschauglas	Mirilla aceite nivel máximo
F ¹	Spia livello olio min.	Min. oil level sight glass	Contrôle niveau huile minimum	Mindestölschauglas	Mirilla aceite nivel mínimo
G	Tappo scarico olio	Oil discharge plug	Bouchon vidange huile	Ölablassschraube	Tapón vaciado de aceite
H	Targhetta identificazione	Pump name plate	Plaquette d'identification	Maschinenschild	Placa de identificación
I	Targhetta olii	Oil plate	Plaquette huiles	Ölempfehlungsschild	Placa tipos de aceites
L	Targhetta rotazione	Rotation plate	Plaquette rotation	Drehungsschild	Placa sentido de giro
N	Zavorratore	Gas ballast valve	Lest d'air	Gasballastventil	Valvula gas-ballast



SCHEDA TECNICA
 DATA SHEET
 FICHE TECHNIQUE
 TECHNISCHE KARTE
 ESQUEMA TÉCNICO

**PVL10 - PVL10/B
(PVL15 - PVL15/B)**

Pag. 1/2 Data 03/01

ST 756.00

		PVL10	PVL10/B	PVL15	PVL15/B
Portata nominale* Nominal capacity* Débit nominal* Caudal nominal* Nennsaugvermögen*	m ³ /h	50Hz	12		17
		60Hz	14		20
Portata effettiva* Effective capacity* Débit effectif* Caudal efectivo* Effektives Saugvermögen*	m ³ /h	50Hz	10		15
		60Hz	12		18
Pressione finale*(assoluta) Ultimate pressure* (abs.) Vide final* (abs.) Presión final* (abs.) Enddruck* (abs.)	mbar	0.5	20	0.5	20
	Pa	50	2000	50	2000
Numero di giri Revolutions number Numéro de révolutions Velocidad de giro Drehzahl	min. ⁻¹	50Hz	1350		
		60Hz	1620		
Potenza motore # Motor power # Puissance moteur # Potencia motor # Motorleistung #	Kw	50Hz	~3	0.37	0.55
			~1	0.55	0.75
		60Hz	~3	0.55	0.75
			~1	0.55	0.75
Caratteristiche motore elettrico Electric motor characteristics Caractéristiques moteur électrique Características motor eléctrico Motoreigenschaften		50Hz	~3	IM B5 230/400 V ±10%	IM B14 230/400 V ±10%
			~1	IM B14 230 V ±10%	
		60Hz	~3	IM B14 275/480 V ±10%	
			~1	IM B14 275 V ±10%	
Livello di pressione acustica Sound pressure level Niveau de pression acoustique Nivel de presión acústica Schalldruckpegel	dB(A) (Pr EN ISO 2151)	50Hz	65		66
		60Hz	66		67
Carica olio Oil charge Charge d'huile Carga de aceite Ölfüllmenge	l		1		1
Peso totale Total weight Poids total Peso total Gesamtgewicht	Kg	50Hz	~3	23	25
			~1	25	27
		60Hz	~3	25	26
			~1	26	27
Peso senza motore Weight without motor Poids sans moteur Peso sin motor Gewicht ohne Motor	Kg		16		16

*Secondo normativa PNEUROP 6602.
*According to Pneurop standard 6602.
*Selon la norme Pneurop 6602.
*Según la normativa Pneurop 6602.
*Nach der Pneurop Norm 6602.

#Valido per temperature fino a 40°C e altitudini inferiori a 1000 m.
#Valid for temperatures up to 40°C and altitudes lower than 1000 m.
#Valable pour températures jusqu'à 40°C et pour altitudes inférieures à 1000 m.
#Válido para temperaturas hasta 40°C y altitudes inferiores a 1000 m.
#Gültig für Temperaturen bis 40°C und für Höhen weniger als 1000 m.

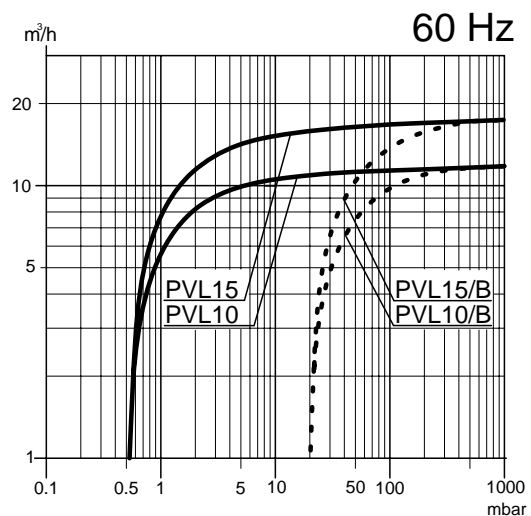
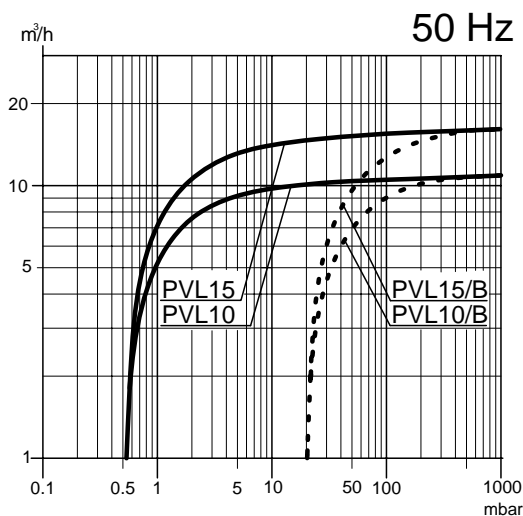

SCHEDA TECNICA
DATA SHEET
FICHE TECHNIQUE
TECHNISCHE KARTE
ESQUEMA TÉCNICO

PVL10 - PVL10/B
PVL15 - PVL15/B

Pag.

2/2

Data

03/01

ST 756.00